

### Key Features & Benefits

- Heavy duty construction
- Instantaneous valve action
- Water sealed valve
- High capacity air handling
- Continuous rapid flow of condensate
- Not affected by sudden pressure changes
- Energy efficient and cost effective
- Will operate against back pressure
- Conforms to federal specification WWT-696

Parts	Description
Head	Class 30 Cast Iron
Body	Class 30 Cast Iron
Bolts	Carbon Steel
Gaskets	Compressed Graphite
Float	Stainless Steel
Plug	Stainless Steel
Seat	Stainless Steel
Air Vent	Stainless Steel/Phosphorus Bronze

### Operating Conditions

#### MLFT2020-8

Maximum operating pressure (PMO)	20 PSI
Maximum operating temperature (TMO)	259 F
Body Design Conditions	
Maximum allowable pressure (PMO)	200 PSI
Maximum allowable temperature (TMA)	450 F

#### MLFT2175-8 & 10

Maximum operating pressure (PMO)	175 PSI
Maximum operating temperature (TMO)	450 F
Body Design Conditions	
Maximum allowable pressure (PMA)	200 PSI
Maximum allowable temperature (TMA)	450 F

### Dimensions

Model #	A	B	C	D	LBS.
MLFT2020-8	12.25"	16"	4.5"	10.75"	44
MLFT2175-8	16.50"	7.50"	4.50"	10.75"	62"
MLFT2175-10	20.50"	8.70"	7.70"	12.80"	117"

"A" Dimension w/o petcock, dedcut 4". Offset for all 1/2"

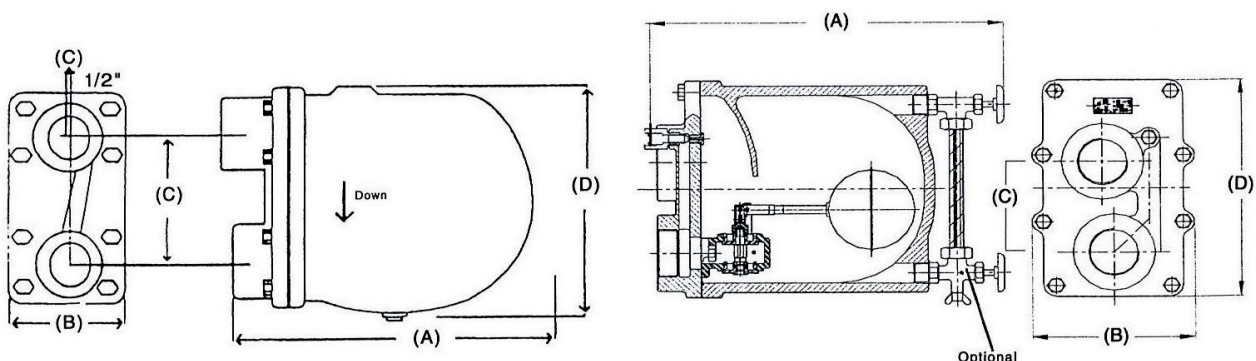

SIZE NPT	MODEL NO.	PRESSURE DIFFERENTIAL (PSIG)															
		1/4	1/2	1	2	5	10	15	20	30	40	60	75	100	125	150	175
2"	MLFT2020-8	6,900	7,522	9,850	11,800	15,600	18,450	21,350	26,500	-	-	-	-	-	-	-	-
2"	MLFT2175-8	8,827	13,192	16,710	20,218	24,771	28,775	30,902	33,030	35,675	38,105	41,938	44,039	47,044	49,796	50,987	52,609
2-1/2"	MLFT2175-10	25,000	31,500	31,500	38,500	46,000	55,500	64,000	68,000	69,500	79,000	85,000	92,000	96,500	103,000	111,000	113,000