

Thermaflo Multivariable Flowmeter

AX2400 Series In-line Vortex



The multivariable flowmeters utilize three primary sensing elements—a vortex shedding velocity sensor, an RTD temperature sensor, and a solid-state pressure transducer—to measure the mass flow rate of gases, liquids and steam.



Systems that use external process measurements to calculate mass flow may not provide adequate compensation

for the fact that process conditions can change radically between the point of velocity measurement and the point where upstream or downstream pressure and temperature measurements are being made. Because the multivariable flowmeter measures all of these parameters in a single location, it delivers a more accurate process measurement.

Integrating multivariable output capability with a single line penetration also simplifies system complexity and helps reduce initial equipment cost, installation cost and maintenance costs.

The AX2400 series is available in a reducing configuration which allows the meter to be reduced internally from the nominal line size thus increasing the units useable measuring range. The AX2400 series has added the ability to power the meter with the POE, Power over Ethernet, functionality with a POE switch or router. This allows for onboard datalogging and the use of Modbus TCP/IP and BACnet IP communications as well as configuration and monitoring via the web interface. The various options and configurations of the meter are intended to help meet your specific application requirements.

Advantage:

- Volumetric or mass flow monitoring of most liquids, gases, and steam
- Multivariable meter delivers mass flow, temperature, pressure, and density readings from a single installed device and reduces initial cost, installation cost and cost-of ownership over the lifetime of the instrument
- Mass flow equations - real gas, ideal gas, AGA 8, API 2540
- Compensated mass flow reading of liquids, gases, and steam
- Energy Monitoring—ability to compute and output energy use
- Easy to install and commission
- Reliable—no moving parts, no fluid to sensor contact
- High accuracy with rangeability up to 100:1
- Temperature up to 750°F
- Pressure up to 1500 psig
- Inline configuraton for pipes from 1/2" - 12" DN15 to DN 300
- Field configurable ranges, outputs and displays
- Remote electronics option available for use in harsh environments or locations with limited access
- 4-20mA loop—powered Mass Meter design saves on energy costs
- HART protocol communications - Standard
- Modbus RTU, BACnet MS/TP, Modbus TCP/IP and BACnet IP communications available
- Ethernet and POE interface available
- FM, FMC, ATEX, IECEx Approved



Thermaflo Inc.
2880 Fair Avenue
Newberry, South
Carolina 29108
704-940-1228

Principle of Operation

Vortex flowmeters measure flows of liquid, gas and steam by detecting the frequency at which vortices are alternately shed from a bluff body. According to proven laws of physics, the frequency at which the vortices are alternately shed is directly proportional to the flow velocity.

As flow passes a bluff body in the flow stream, the vortices create low and high pressure zones behind the bluff body, or shedder bar. The AX2400 series uses a piezoelectric crystal sensor to detect the pressure exerted by the vortices on the velocity sensor. The piezoelectric converts these “pulses” into electrical signals. The meter uses an all welded sensor design to create a robust sensor and to minimize potential leakages.

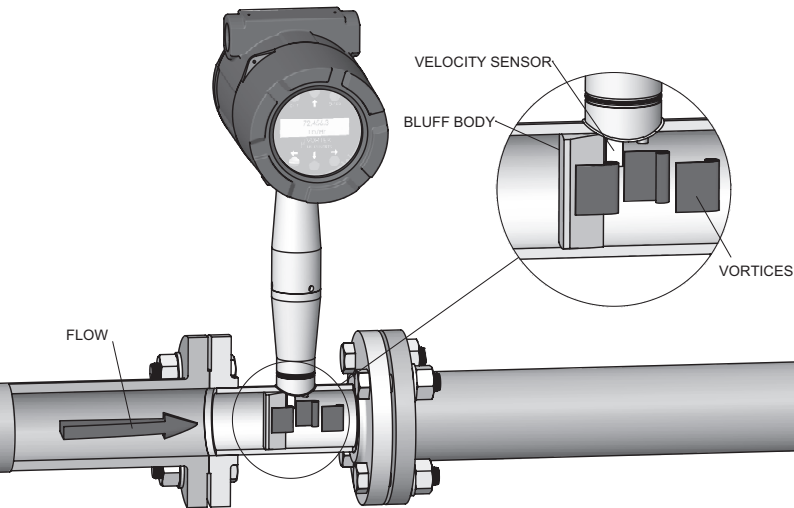

Model AX2422

The Model AX2422 offers you flow computer functionality in a compact field device. This multivariable instrument incorporates temperature and pressure sensors to provide an instantaneous reading of the compensated mass flow rate of gases, liquids and steam. In addition to outputs for totalized mass and alarm settings, the field-configurable electronics deliver up to three analog 4-20 mA outputs of five process measurements, including volumetric flow rate, mass flow rate, pressure, temperature and density.

Model AX2411

The Model AX2411 integrates a precision 1000 Ohm platinum RTD temperature sensor that can be used to calculate and output a compensated mass reading. This device is typically used to measure flow rates of saturated steam.

Model AX2400

The Model AX2400 delivers a direct reading of volumetric flow rate—generally the most cost-effective solution for liquid flow monitoring—in applications ranging from general water flows to hydrocarbon fuel flow measurement.

Energy Monitoring Option

The Energy Monitoring option permits real-time calculation of energy consumption for a facility or process. The meter can be programmed to measure steam, hot water or chilled water. The flowmeter with this option monitors one side of the process, either sent or returned, and uses the input from a second separate temperature sensor on the opposite leg of the process to calculate the change in energy. Selectable energy units include Btu, joules, calories, Watt-hours, Megawatt-hours and Horsepower-hours. The local or remote electronics indicate two temperatures, delta T, mass total and energy total.

Model AX2266

Similar to AX2422 but with the option for an external input (T or P) via RTD or 4-20mA or one of each.

Performance Specifications

Accuracy

Mass flow rate accuracy for gas and steam based on 50-100% of pressure range.

AX2400 Series Multiparameter Inline Vortex Meter		
Process Variables	Liquids	Gas & Steam
Volumetric Flow Rate	± .7% of Rate	± 1% of Rate
Mass Flow Rate	± 1% of Rate	± 1.5% of Rate
Temperature	± 2°F (± 1°C)	± 2°F (± 1°C)
Pressure	± .3% of Full Scale	± .3% of Full Scale
Density	± .3% of Reading	± .5% of Reading

Repeatability

Mass Flow Rate ± .2% of rate
 Volumetric Flow Rate ± .1% of rate
 Temperature ± .2°F (± .1°C)
 Pressure ± .05% of full scale
 Density ± .1% of reading

Stability Over 12 Months

Mass Flow Rate ± .2% of rate
 Volumetric Flow Rate ± negligible
 Temperature ± .9°F (± .5°C)
 Pressure ± .1% of full scale
 Density ± .1% of reading

Response Time

Adjustable from 1 to 100 seconds

Operating Specifications

Any gas, liquid or steam compatible with 316L stainless steel, C276 hastelloy or A105 carbon steel. Not recommended for multi-phase fluids.

Process and Ambient Temperature

Process Standard Temperature (code S): -330 to 500°F (-200 to 260°C)
 Process High Temperature (code H): to 750°F (400°C)
 Ambient Operating: -40 to 140°F (-40 to 60°C)
 Ambient Storage: -40 to 185°F (-40 to 85°C)

Pressure Transducer Ratings			
Full Scale Operating Pressure		Max. Over-Range Pressure	
psia	bara	psia	bara
30	2	60	4
100	7	200	14
300	20	600	40
500	35	1000	70
1500	100	2750	175

Power Requirements

Input Power Code "1": 12-36 VDC, 25mA, 1W max, loop powered (single output)
 Input Power Code "2": 12-36 VDC, 300mA, 9W max, (multiple outputs)
 Input Power Code "3": 100-240 VAC, 50/60Hz line power, 5W (multiple outputs)
 Input Power Code "4": 12-28 VDC or Power over Ethernet, 5W maximum (multiple outputs)

Display

Alphanumeric 2 line x 16 character LCD digital display
 Six pushbuttons for full field configuration
 Pushbuttons can be operated with magnetic wand without removal of enclosure covers
 Display can be mounted in 90° intervals for better viewing

Output Signals

Analog: 4-20 mA
 Alarm: Solid state relay, 40 VDC
 Totalizer Pulse: 50 millisecond pulse, 40 VDC
 Volumetric or Loop Powered Mass: One analog, one totalizer pulse, HART
 Multivariable option: Up to three analog signals, three alarms, one totalizer pulse, HART
 Multivariable option: Modbus or BACnet process monitoring

Physical Specifications

Wetted Materials

Standard 316L Stainless Steel, plus

- Optional Carbon Steel or Hastelloy C
- DuPont Teflon® based thread sealant on models with pressure transducer

Approvals

FM, FMC CLASS I, DIV. 1, GROUPS B,C,D
 CLASS II/III, DIV. 1, GROUPS E,F,G
 Type 4X and IP66, T6, Ta = -40 to 60°C

ATEX II 2 G Ex d IIB + H2 T6
 II 2 D EX tD A21 IP66 T85°C, Ta = -40 to 60°C

IECEX Ex d IIB + H2 T6
 Ex tD A21 IP66 T85°C, Ta = -40 to 60°C



Sizing Considerations

Piping Conditions

Condition	Pipe Diameters, D	
	Upstream	Downstream
One 90° elbow before meter	10D	5D
Two 90° elbows before meter	15D	5D
Two 90° elbows before meter, out of plane	30D	10D
Reduction before meter	10D	5D
Expansion before meter	20D	5D
Partially open valve	30D	10D

Velocity Range

Maximum velocity, liquid: 30 feet/sec (9 meters/second)
 Minimum velocity, liquid: 1 foot/sec (.3 meters/second)
 Maximum velocity, gas or steam: See Table Below
 Minimum velocity, gas or steam feet/sec (meters/second):

$$\sqrt{\frac{5}{\text{density (Lb/ft}^3)}} \quad \sqrt{\frac{6.1}{\text{density (kg/m}^3)}}$$

Pressure Drop Equations

$\Delta P = 0.00024pV^2$ English Units (ΔP in psi, p in lb/ft³, V in ft/sec)
 $\Delta P = 0.000011pV^2$ Metric Units (ΔP in bar, p in kg/m³, V in m/sec)

Consult the Azbil Sizing Program @azbil.sizingapp.com for easy calculation of flow range.

Water Minimum and Maximum Flow Rates

Rate	Nominal Pipe Size (in)										
	0.5	0.75	1	1.5	2	3	4	6	8	10	12
GPM min	0.9	1.4	2.2	5.5	9.2	21	36	81	142	224	317
GPM max	22	40	67	166	276	618	1076	2437	4270	6715	9501
Rate	Nominal Pipe Size (mm)										
	15	20	25	40	50	80	100	150	200	250	300
M ³ /hr min	0.2	0.3	0.5	1.3	2.1	4.7	8.1	18	32	51	72
M ³ /hr Max	5	9	15	38	63	140	244	554	970	1525	2158

Gas or Steam Max Velocity

Rate	Nominal Pipe Size (in)										
	0.5	0.75	1	1.5	2	3	4	6	8	10	12
FT/SEC Max	175	250	250	300	300	300	300	300	300	300	300
Rate	Nominal Pipe Size (mm)										
	15	20	25	40	50	80	100	150	200	250	300
M/SEC Max	53	76	76	90	90	90	90	90	90	90	90

Typical Saturated Steam Minimum and Maximum Flow Rates (lb/hr)											
Nominal Pipe Size (in)											
Pressure	0.5	0.75	1	1.5	2	3	4	6	8	10	12
5 psig	6.5	12	20	49	82	183	318	722	1264	1988	2813
	52	122	265	650	1087	2431	4231	9594	16806	26429	37395
100 psig	15	27	46	112	187	419	728	1652	2893	4550	6438
	271	639	1386	3405	5690	12729	22156	50233	87998	138386	195803
200 psig	20	37	62	151	253	565	983	2229	3905	6141	8689
	493	1163	2525	6203	10365	23184	40354	91494	160279	252055	356635
300 psig	24	45	74	182	304	680	1184	2685	4704	7397	10466
	716	1688	3664	9000	15040	33642	58556	132763	232575	365747	517499
400 psig	28	51	85	209	349	780	1358	3079	5393	8481	12000
	941	2220	4816	11831	19770	44222	76971	174516	305717	480771	680247
500 psig	31	57	95	233	389	870	1514	3433	6014	9457	13381
	1170	2760	5988	14711	24582	54987	95710	217001	380148	597812	845850

Typical Saturated Steam Minimum and Maximum Flow Rates (kg/hr)											
Nominal Pipe Size (mm)											
Pressure	15	20	25	40	50	80	100	150	200	250	300
0 barg	3	5	8	19	32	72	126	286	500	786	1113
	18	42	91	224	375	838	1459	3309	5797	9116	12898
5 barg	6	11	18	45	75	167	290	658	1153	1813	2565
	95	224	485	1192	1992	4455	7754	17581	30799	48434	68530
10 barg	8	15	24	59	99	222	387	877	1537	2417	3419
	168	397	862	2118	3539	7915	13777	31237	54720	86053	121758
15 barg	9	17	29	71	119	266	463	1050	1840	2893	4094
	241	569	1236	3036	5073	11347	19750	44779	78444	123360	174543
20 barg	11	20	33	81	136	304	529	1199	2100	3303	4673
	314	742	1610	3956	6611	14787	25738	58355	102226	160761	227463
30 barg	13	24	40	99	165	369	642	1455	2548	4007	5669
	463	1092	2370	5822	9729	21763	37880	85884	150451	236599	334766

Typical Air Minimum and Maximum Flow Rates (SCFM) Air at Standard Process Conditions 70°F, 14.6959 PSIA											
Nominal Pipe Size (in)											
Pressure	0.5	0.75	1	1.5	2	3	4	6	8	10	12
0 psig	1.8	3	5	13	22	50	87	198	347	546	773
	18	41	90	221	369	826	1437	3258	5708	8976	12701
100 psig	5	9	15	38	63	141	245	555	972	1529	2163
	138	325	704	1730	2890	6466	11254	25515	44698	70292	99456
200 psig	7	13	21	52	86	193	335	761	1332	2095	2965
	258	609	1322	3248	5427	12140	21131	47911	83931	131895	186752
300 psig	8	15	25	63	104	234	407	922	1615	2540	3594
	380	896	1944	4775	7978	17847	31064	70431	123375	194025	274529
400 psig	10	18	29	72	120	269	467	1060	1857	2920	4132
	502	1183	2568	6309	10542	23580	41043	93057	163000	256358	362724
500 psig	11	20	33	80	134	300	521	1182	2071	3257	4608
	624	1472	3195	7849	13115	28034	51063	115775	203000	318941	451272

Typical Air Minimum and Maximum Flow Rates (nm³/hr) Air at Standard conditions of 20°C, 1.0133 BARA											
Nominal Pipe Size (mm)											
Pressure	15	20	25	40	50	80	100	150	200	250	300
0 barg	3	5	9	21	36	79	138	313	549	863	1221
	28	66	142	350	584	1307	2275	5157	9034	14207	20102
5 barg	7	13	21	52	87	194	337	764	1339	2105	2979
	165	390	847	2080	3476	7775	13533	30682	53749	84525	119596
10 barg	9	17	29	70	117	262	457	1035	1814	2853	4036
	304	716	1554	3819	6381	14273	24844	56329	98676	155178	219563
15 barg	11	21	34	85	142	317	551	1250	2190	3444	4873
	442	1044	2265	5565	9299	20801	36205	82087	143801	297386	319968
20 barg	13	24	40	97	162	363	632	1434	2511	3949	5588
	582	1373	2979	7318	12229	27354	47612	107949	189105	297386	420775
30 barg	16	29	48	118	198	442	770	1745	3057	4807	6801
	862	2034	4414	10843	18119	40529	70544	159942	280187	440621	623439

Turndown

Turndown is application dependent. Consult the Azbil Sizing Program @azbil.sizingapp.com for exact values.

Turndown can exceed 100:1

Dimensional Outline: Inline Flanged Models

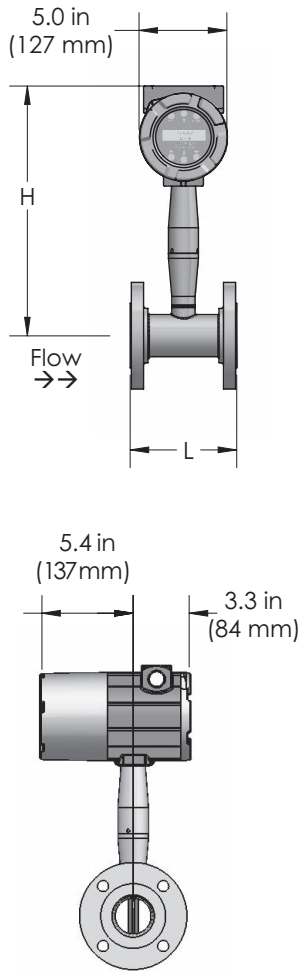

Flow Meter Nominal Size	L	H	Approximate Weight		
			ANSI 150 (PN 16)	ANSI 300 (PN 40)	ANSI 600 (PN 64)
1/2 inch (15mm)	7.9 in (200 mm)	13.5 in (343 mm)	12 Lb (5.5 kg)	12.5 Lb (5.7 kg)	13.4 Lb (6.1 kg)
3/4 inch (20 mm)	7.9 in (200 mm)	13.5 in (343 mm)	13 Lb (5.9 kg)	14.6 Lb (6.6 kg)	15.6 Lb (7.1 kg)
1 inch (25 mm)	7.9 in (200 mm)	13.5 in (343 mm)	13.5 in (6.1 kg)	16.3 Lb (7.4 kg)	16.4 Lb (7.5 kg)
1-1/2 inch (40 mm)	7.9 in (200 mm)	13.8 in (351 mm)	16.3 Lb (7.4 kg)	23.3 Lb (10.6 kg)	24.6 Lb (11.2 kg)
2 inch (50 mm)	7.9 in (200 mm)	14.0 in (356 mm)	21.2 Lb (9.6 kg)	26.8 Lb (12.2 kg)	33.2 Lb (15.1 kg)
3 inch (80 mm)	7.9 in (200 mm)	14.6 in (371 mm)	33 Lb (15.0 kg)	41.0 Lb (18.6 kg)	56.1 Lb (25.5 kg)
4 inch (100 mm)	9.84 in (250 mm)	15.1 in (384 mm)	45.8 Lb (20.8 kg)	66.8 Lb (30.3 kg)	96.0 Lb (43.6 kg)
6 inch (150 mm)	11.81 in (300 mm)	16.2 in (411 mm)	68.3 Lb (31.0 kg)	106.3 Lb (48.2 kg)	194.3 Lb (88.2 kg)
8 inch (200 mm)	11.81 in (300 mm)	17.2 in (437 mm)	112.4 Lb (51.0 kg)	168.4 Lb (76.5 kg)	299.0 Lb (136 kg)
10 inch (250 mm)	15 in (381 mm)	18.2 in (462 mm)	188.3 Lb (85.5 kg)	262.3 Lb (119.1 kg)	462.3 Lb (209.9 kg)
12 inch (300 mm)	17.7 in (450 mm)	19.2 in (488 mm)	298.6 Lb (135.6 kg)	402.6 Lb (182.8 kg)	606.6 Lb (275.4 kg)

Add 11 lb (5 KG) for remote electronics

Dimensional Outline: Inline Reducing Flanged Models

Flow Meter Nominal Size	L	H	Approximate Weight		
			ANSI 150 (PN 16)	ANSI 300 (PN 40)	ANSI 600 (PN 64)
3/4 inch (20 mm) X 1/2 inch (15mm)	7.9 in (200 mm)	13.5 in (343 mm)	13 Lb (5.9 kg)	14.6 Lb (6.6 kg)	15.6 Lb (7.1 kg)
1 inch (25 mm) X 1/2 inch (15 mm)	7.9 in (200 mm)	13.5 in (343 mm)	13 Lb (5.9 kg)	16.3 Lb (7.4 kg)	16.4 Lb (7.5 kg)
1-1/2 inch (40 mm) X 1 inch (25 mm)	7.9 in (200 mm)	13.0 in (351 mm)	13.4 Lb (6.1 kg)	23.3 Lb (10.6 kg)	24.6 Lb (11.2 kg)
2 inch (50 mm) X 1-1/2 inch (40 mm)	7.9 in (200 mm)	14.0 in (356 mm)	16.3 Lb (7.4 kg)	26.8 Lb (12.2 kg)	33.2 Lb (15.1 kg)
3 inch (80 mm) X 2 inch (50 mm)	7.9 in (200 mm)	14.6 in (371 mm)	21.2 Lb (9.6 kg)	41.0 Lb (18.6 kg)	56.1 Lb (25.5 kg)
4 inch (100 mm) X 3 inch (80 mm)	9.84 in (250 mm)	15.1 in (384 mm)	33 Lb (15.0 kg)	66.8 Lb (30.3 kg)	96.0 Lb (43.6 kg)
6 inch (150 mm) X 4 inch (100 mm)	11.81 in (300 mm)	16.2 in (411 mm)	45.8 Lb (20.8 kg)	106.3 Lb (48.2 kg)	194.3 Lb (88.2 kg)
8 inch (200 mm) X 6 inch (150 mm)	11.81 in (300 mm)	17.2 in (437 mm)	68.3 Lb (31.0 kg)	168.4 Lb (76.5 kg)	299.0 Lb (136 kg)
10 inch (250 mm) X 8 inch (200 mm)	15.0 in (381 mm)	18.2 in (462 mm)	188.3 Lb (85.5 kg)	262.3 Lb (119.1 kg)	462.3 Lb (209.9 kg)
12 inch (300 mm) X 10 inch (250 mm)	17.7 in (450 mm)	19.2 in (488 mm)	298.6 Lb (135.6 kg)	402.6 Lb (182.8 kg)	606.6 Lb (275.4 kg)

Add 11 lb (5 KG) for remote electronics

Dimensional Outline: Inline Wafer Models

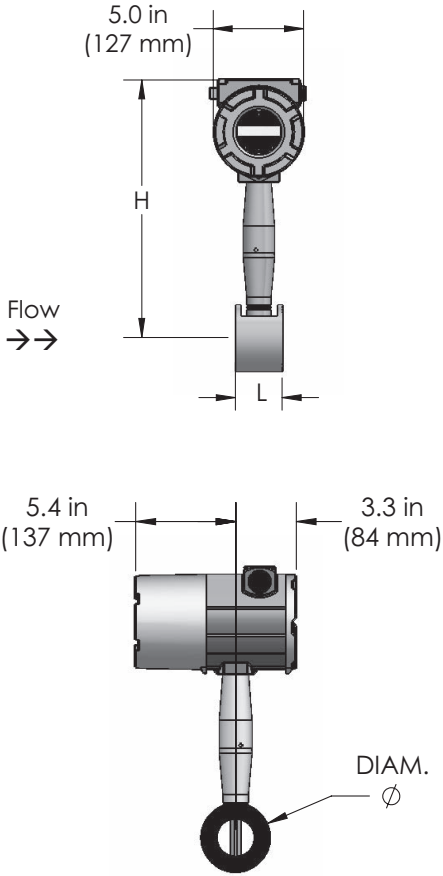

Flow Meter Nominal Size	L	H	Diameter	Approximate Weight
1/2 inch (15mm)	2.56 in (65 mm)	13.5 in (343 mm)	1.38 in (35 mm)	9.2 Lb (4.2 kg)
3/4 inch (20 mm)	2.56 in (65 mm)	13.5 in (343 mm)	1.69 in (43 mm)	9.5 Lb (4.3 kg)
1 inch (25 mm)	2.56 in (65 mm)	13.5 in (343 mm)	2.0 in (51 mm)	10.3 Lb (4.7 kg)
1-1/2 inch (40 mm)	2.56 in (65 mm)	13.8 in (351 mm)	2.88 in (73 mm)	12.1 Lb (5.5 kg)
2 inch (50 mm)	2.56 in (65 mm)	14.0 in (356 mm)	3.62 in (92 mm)	14.1 Lb (6.4 kg)
3 inch (80 mm)	2.56 in (65 mm)	14.6 in (371 mm)	5.0 in (127 mm)	18.7 Lb (8.5 kg)
4 inch (100 mm)	2.56 in (65 mm)	15.1 in (384 mm)	6.19 in (157 mm)	23.4 Lb (10.6 kg)

Add 11 lb (5 KG) for remote electronics

Dimensional Outline RD: Inline Reducing Wafer Models

Flow Meter Nominal Size	L	H	Diameter	Approximate Weight
3/4 inch (20 mm) X 1/2 inch (15mm)	2.56 in (65 mm)	13.5 in (343 mm)	1.38 in (35 mm)	9.2 Lb (4.2 kg)
1 inch (25 mm) X 3/4 inch (20 mm)	2.56 in (65 mm)	13.5 in (343 mm)	1.69 in (43 mm)	9.50 Lb (4.3 kg)
1-1/2 inch (40 mm) X 1 inch (25 mm)	2.56 in (65 mm)	13.8 in (351 mm)	2.0 in (51 mm)	10.3 Lb (4.7 kg)
2 inch (50 mm) X 1-1/2 inch (40 mm)	2.56 in (65 mm)	13.8 in (351 mm)	2.88 in (73 mm)	12.1 Lb (5.5 kg)
3 inch (80 mm) X 2 inch (50 mm)	3.94 in (100 mm)	14.6 in (371 mm)	5.0 in (127 mm)	23.9 Lb (8.5 kg)
4 inch (100 mm) X 3 inch (80 mm)	4.72 in (120 mm)	15.1 in (384 mm)	6.19 in (157 mm)	35.2 Lb (10.6 kg)

Add 11 lb (5 KG) for remote electronics

Dimensional Outline: Remote Electronics Option

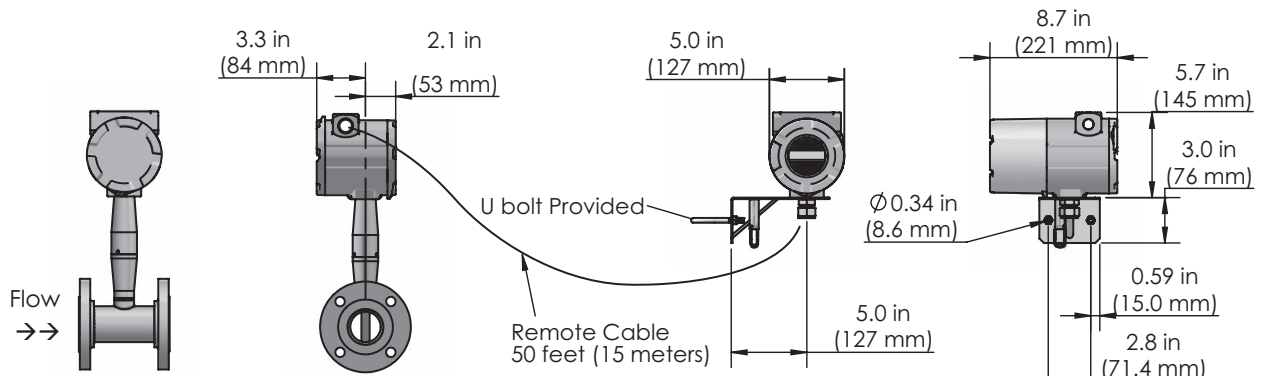

Model Code Information - Azbil AX2400 Series Inline Vortex Flowmeter

Parent Number Code

AX24	Azbil Inline Vortex Flow Meter
AX24R	Azbil Inline Reducing Vortex Flow Meter

Feature 1: Multivariable Options (AX24)

00	Volumetric Flow Meter for liquid, gas and steam
11	Velocity and Temperature Sensors. Mass measurement with temperature compensation
22	Velocity, Temperature and Pressure Sensors. Mass measurement with pressure and temperature compensation
33	Velocity, Temperature and External 4-20mA input (T or P)
44	Velocity and Temperature Sensors. Energy Monitoring option. Permits real-time calculation of energy consumption
55	Velocity, Temperature and Pressure Sensors. Energy Monitoring option. Permits real-time calculation of energy consumption
66	Velocity, External RTD Temperature input, External 4- 20mA input (T or P)
77	Velocity, External RTD Temperature input, External 4-20mA input (T or P). Energy Monitoring option. Permits real-time calculation of energy consumption

Feature 1: Multivariable Options (AX24R)

0	Volumetric Flow Meter for liquid, gas and steam
1	Velocity and Temperature Sensors. Mass measurement with temperature compensation
2	Velocity, Temperature and Pressure Sensors. Mass measurement with pressure and temperature compensation
3	Velocity, Temperature and External 4-20mA input (T or P)
4	Velocity and Temperature Sensors. Energy Monitoring option. Permits real-time calculation of energy consumption
5	Velocity, Temperature and Pressure Sensors. Energy Monitoring option. Permits real-time calculation of energy consumption
6	Velocity, External RTD Temperature input, External 4-20mA input (T or P)
7	Velocity, External RTD Temperature input, External 4-20mA input (T or P). Energy Monitoring option. Permits real-time calculation of energy consumption

Feature 2: Flow Body (AX24)

015	1/2-inch Nominal Bore (15mm)
020	3/4-inch Nominal Bore (20mm)
025	1-inch Nominal Bore (25mm)
040	1.5-inch Nominal Bore (40mm)
050	2-inch Nominal Bore (50mm)
080	3-inch Nominal Bore (80mm)
100	4-inch Nominal Bore (100mm)
150	6-inch Nominal Bore (150mm)
200	8-inch Nominal Bore (200mm)
250	10-inch Nominal Bore (250mm)
300	12-inch Nominal Bore (300mm)

Feature 2: Reducing Flow Body (AX24R)

020	3/4-inch (20mm) by 1/2 inch Nominal Bore Reducing Meter (15mm)
025	1-inch (25mm) by 1/2 inch Nominal Bore Reducing Meter (15mm)
040	1.5-inch (40mm) by 1 inch Nominal Bore Reducing meter (25mm)
050	2-inch (50mm) by 1.5-inch Nominal Bore Reducing Meter (40mm)
080	3-inch (80mm) by 2-inch Nominal Bore Reducing Meter (50mm)
100	4-inch (100mm) by 3-inch Nominal Bore Reducing Meter (80mm)
150	6-inch (150mm) by 4-inch Nominal Bore Reducing Meter (100mm)
200	8-inch (200mm) by 6-inch Nominal Bore Reducing Meter (150mm)
250	10-inch (250mm) by 8-inch Nominal Bore Reducing Meter (200mm)
300	12-inch (300mm) by 10-inch Nominal Bore Reducing Meter (200mm)

Feature 3: Meter Body Material

C	Carbon Steel (1.5" and up)
S	316 Stainless Steel
H	Hastelloy

Feature 4: Process Connection

FA	ANSI 150# Flange
FB	ANSI 300# Flange
FC	ANSI 600# Flange
WC	Wafer ANSI 600#
D1	PN 16
D2	PN 40
D3	PN 63
J1	JIS 10K
J2	JIS 20K
J3	JIS 30K

Model Code Information - Azbil AX2400 Series Inline Vortex Flowmeter

Feature 5: Electronics Enclosure

LE	Local Electronics NEMA 4X Enclosure Mounted on Meter
R1	Remote Electronics NEMA 4X Enclosure. 3 Meter Cable
R2	Remote Electronics NEMA 4X Enclosure. 5 Meter Cable
R3	Remote Electronics NEMA 4X Enclosure. 10 Meter Cable
R4	Remote Electronics NEMA 4X Enclosure. 10 Meter Cable
R6	Remote Electronics NEMA 4X Enclosure. 20 Meter Cable
R7	Remote Electronics NEMA 4X Enclosure. 25 Meter Cable
R8	Remote Electronics NEMA 4X Enclosure. 30 Meter Cable
R9	Remote Electronics NEMA 4X Enclosure. 35 Meter Cable.
RY	Remote Electronics NEMA 4X Enclosure. Custom Length Cable (Max. 50 Meters)

Feature 6: Display Options

D	Digital Display and Programming Buttons
----------	---

Feature 7: Input Power

1	12-36 VDC, 25mA, 1W max. required on loop powered meters, Output Code "A" only
2	12-36 VDC, 300mA, 9W max. - use with Output Codes "B", "C", "D", "E", "F", and "G"
3	100-240 VAC, 50/60Hz line power, 5W max. - use with Output Codes "B", "C", "D", "E", "F", and "G"
4	12-28 VDC or Power over Ethernet, 5 Watts maximum, Not loop powered, required on "H", "I", "J" and "K"

Feature 8: Output

A	Loop powered option - one analog output (4-20mA), one alarm, one pulse, HART Communication Protocol (Input Power Option Code "1" only)
B	One analog output (4-20mA), one alarm, one pulse, HART Communication Protocol (Input Power Option Code "2" or "3" only)
C	One analog output (4-20mA), one alarm, one pulse, MODBUS RTU Communication Protocol (Input Power Option Code "2" or "3" only)
D	Three analog outputs (4-20mA), three alarms, one pulse, HART Communication Protocol (Input Power Option Code "2" or "3" only)
E	Three analog outputs (4-20mA), three alarms, one pulse, MODBUS RTU Communication Protocol (Input Power Option Code "2" or "3" only)
F	One analog output (4-20mA), one alarm, one pulse, BACnet MS/TP Communication Protocol (Input Power Option Code "2" or "3" only)
G	Three analog outputs (4-20mA), three alarms, one pulse, BACnet MS/TP Communication Protocol (Input Power Option Code "2" or "3" only)
H	One analog output (4-20 mA), one alarm, one pulse, one scaled frequency, MODBUS TCP/IP Communication Protocol (Input Power Code "4")
I	One Analog Output (4-20mA), one alarm, one pulse, one scaled frequency, BACnet /IP Communication Protocol (Input Power Code "4")
J	Three analog outputs (4-20 mA), three alarms, one pulse, one scaled frequency, Ethernet, MODBUS TCP/IP Communication Protocol (Input Power Code "4")
K	3 Analog Outputs (4-20mA), three alarms, one pulse, one scaled frequency output, Ethernet, BACnet /IP Communication Protocol (Input Power Code "4")

Feature 9: Temperature Options

S	Standard temperature. Process temperature -330° to 500°F (-200° to 260°C)
H	High temperature. Process temperatures up to 750°F (400°C)

Feature 10: Pressure Options

X	No Pressure Sensor
A	Maximum 30 psia (2 bara), Proof 60 psia (4 bara)
B	Maximum 100 psia (7 bara), Proof 200 psia (14 bara)
C	Maximum 300 psia (20 bara), Proof 600 psia (41 bara)
D	Maximum 500 psia (34 bara), Proof 1000 psia (64 bara)
E	Maximum 1500 psia (100 bara), Proof 2500 psia (175 bara)

Feature 11: Options

XX	No Options
MC	Material Certificates--US Mill certs on all wetted parts
PT	Pressure Test Certificate
CC	Certificate of Conformance
NC	NACE Certification
O2	Oxygen Cleaning
PD	PED certified bodies (Stainless steel meters only)
A1	25' Armored Cable with Glands (ATEX, IECEX) AX2200 Meter only - Adder to Remote Option
A2	50' Armored Cable with Glands (ATEX, IECEX) AX2200 Meter only - Adder to Remote Option
A3	25' Armored Cable with Glands (ATEX, IECEX) AX2211 & AX2222 Meter only - Adder to Remote Option
A4	50' Armored Cable with Glands (ATEX, IECEX) AX2211 & AX2222 Meter only - Adder to Remote Option