



## Models 6252 and 6254

**ASME Section I Steam and ASME Section VIII, Air, Steam and Gas 'UV' National Board Certified.  
Model 6254 ASME Section IV 'HV', National Board Certified. PED Certified for Non-Hazardous Gas.**

### Features

- **Heavy duty construction** of high quality cast iron with SS semi-nozzle trim and disc.
- **Bolted bonnet design** for easy maintenance.
- **Seats lapped** to optical flatness.
- **Dual control rings** offer easy adjustability for precision opening with minimum preopen or simmer and exact blowdown control.
- **Heavy duty lift lever assembly.**
- **Every valve tested/inspected** for pressure setting, blowdown and leakage.
- **All adjustments are factory sealed** to prevent tampering or disassembly.

### Model Descriptions

**Model 6252:** Cast iron, enclosed spring, SS trim.

**Model 6254:** Same as Model 6252 except certified for ASME Code Section IV - Low pressure steam heating boilers. Set 15 psig [1.0 barg] only. J through P orifice only.

### Applications

- Steam Boilers and Generators.
- Pressure Reducing Stations.
- Air/Gas Compressors - reciprocating or rotary.
- Pressure Vessels - including tanks, receivers, intercoolers, oil/gas separators, lines.

### Pressure and Temperature Limits

#### Model 6252:

10 to 250 psig [0.7 to 17.2 barg]  
-20° to 406°F [-28° to 208°C]



## Models 6252 and 6254

### Parts and Materials

Models 6252 and 6254		
No.	Part Name	Material
1	Body	Cast Iron, A126 CL A or B
2	Semi Nozzle	SS, SA351 CF8M <sup>5</sup>
3	Warn Ring Locking Screw	Brass, B16 H02
4	Warn Ring Locking Pin	SS, A582 TY 416
5	Guide	Bronze, B584 C84400
6	Guide Locking Screw	Brass, B16 H02
7	Guide Locking Pin	SS, A582 TY 416
8	Stem End	SS, A582 TY 416
9	Spring Step	Brass, B16 H02
10	Compression Screw	Brass, B16 H02
11	Lever	Iron, A536 65 45 12
12	Compression Screw Lock Nut	SS, SA479 316 SS
13	Lifting Disc Nut	Steel, A108 1018
14	Cap	Iron, A536 65 45 12
15	Lifting Disc	SS, SA479 316 SS
16	Lever Pin	Steel, A108 1018
17	Lever Pin Washer	Steel, A108 1018
18	Lever Cotter Pin	Steel, A108 1018
19	Stem	SS, A582 TY 416
20	Cap Set Screw	Steel, A108 1018
21	Bonnet	Cast Iron, A126 CL A or B
22	Spring	Steel, A229, Aluminum Coated <sup>2</sup>
23	Bonnet Bolt	Steel, A193-B7/194-7
24	Disc	SS, SA479 316 SS <sup>6</sup>
25	Warn Ring	Bronze, B584-C84400 <sup>3</sup>
26	Gag Screw <sup>4,1</sup>	Steel, A108 1018 <sup>1</sup>
27	Wire Seal	Lead Seal, Aluminum Wire <sup>7</sup>

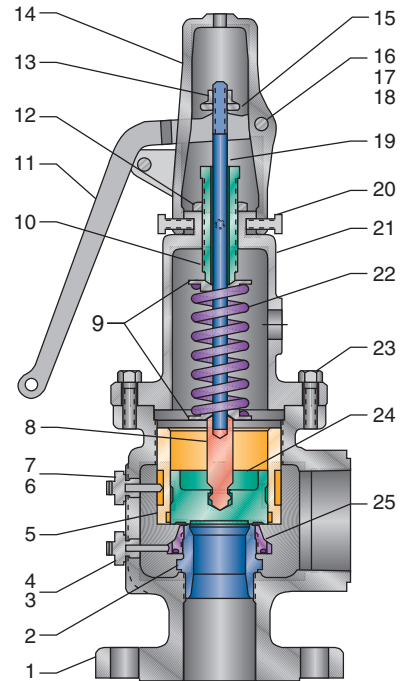

### Notes

1. Not shown on assembly.
2. SS A313-631 for 'J' orifice.
3. Brass B16-H02 for 'J' orifice.
4. Optional.
5. SS-SA479-316 for 'N' and 'P' orifice.
6. SS-SA351-C8FM for 'Q' and 'R' orifice.



## Models 6252 and 6254

### Dimensions

Models 6252 and 6254													
Model <sup>1</sup>	Orifice	Connections				Valve Dimensions in [mm]						Approximate Weight	
		ANSI Standard, in [mm]		ANSI Standard, in [mm]		A		B		C		lb	[kg]
		Inlet <sup>2</sup>	Outlet <sup>3</sup>										
625*AJG	J	1½ [38.1] FPT	2½ [63.5] FPT	4¼ [108.0]	3½ [88.9]	18 [457.2]	40 [18.2]						
625*FJG	J	1½ [38.1] F	2½ [63.5] FPT	4¼ [108.0]	3½ [88.9]	18 [457.2]	40 [18.2]						
625*FJH	J	2 [50.8] F	2½ [63.5] FPT	4¼ [108.0]	3½ [88.9]	18 [457.2]	42 [19.1]						
625*FJJ	J	2½ [63.5] F	2½ [63.5] FPT	4¼ [108.0]	3½ [88.9]	18 [457.2]	45 [20.5]						
625*AKH	K	2 [50.8] FPT	3 [76.2] FPT	4⅝ [117.6]	4 [101.6]	18¼ [463.6]	43 [19.5]						
625*FKH	K	2 [50.8] F	3 [76.2] FPT	4⅝ [117.6]	4 [101.6]	18¼ [463.6]	52 [23.6]						
625*FKJ	K	2½ [63.5] F	3 [76.2] FPT	4⅝ [117.6]	4 [101.6]	18¼ [463.6]	52 [23.6]						
625*FKK	K	3 [76.2] F	3 [76.2] FPT	4⅝ [117.6]	4 [101.6]	18¼ [463.6]	55 [25.0]						
625*ALJ	L	2½ [63.5] FPT	4 [101.6] FPT	5½ [139.7]	4 <sup>13/16</sup> [122.2]	21½ [546.1]	74 [33.6]						
625*FLJ	L	2½ [63.5] F	4 [101.6] FPT	5½ [139.7]	4 <sup>13/16</sup> [122.2]	21½ [546.1]	82 [37.3]						
625*FLK	L	3 [76.2] F	4 [101.6] FPT	5½ [139.7]	4 <sup>13/16</sup> [122.2]	21½ [546.1]	86 [39.1]						
625*FLM	L	4 [101.6] F	4 [101.6] FPT	5½ [139.7]	4 <sup>13/16</sup> [122.2]	21½ [546.1]	97 [44.1]						
625*AMK	M	3 [76.2] FPT	4 [101.6] FPT	5⅝ [142.7]	5⅛ [130.0]	21 <sup>11/16</sup> [550.9]	90 [40.9]						
625*FMK	M	3 [76.2] F	4 [101.6] FPT	5⅝ [142.7]	5⅛ [130.0]	21 <sup>11/16</sup> [550.9]	100 [45.5]						
625*FMM	M	4 [101.6] F	4 [101.6] FPT	5⅝ [142.7]	5⅛ [130.0]	21 <sup>11/16</sup> [550.9]	107 [48.6]						
625*KNM	N	4 [101.6] F	6 [152.4] F	6¾ [171.5]	7¼ [184.2]	22½ [571.5]	197 [89.5]						
625*KPM	P	4 [101.6] F	6 [152.4] F	6¾ [171.5]	7¼ [184.2]	25 <sup>13/16</sup> [655.6]	197 [89.5]						
625*KQP	Q	6 [152.4] F	8 [203.2] F	9¼ [234.9]	10 [254.0]	39⅛ [993.8]	493 [224.0]						
625*KRP	R	6 [152.4] F	8 [203.2] F	9¼ [234.9]	10 [254.0]	39⅛ [993.8]	507 [230.0]						

Dimensions are for reference only.

#### Notes

1. Replace asterisk with desired model number.
2. Inlet Flanges are ANSI B16. 1-250#.
3. Outlet Flanges are ANSI B16. 1-125#.

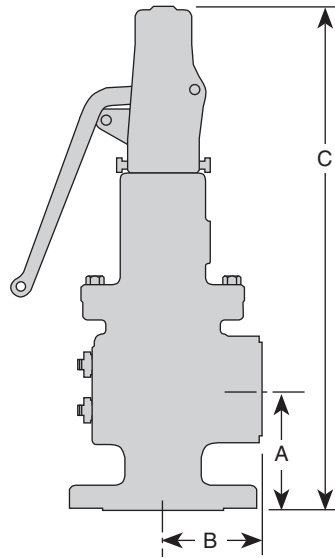

## Models 6252 and 6254

### Capacities for Model 6252

Non-code <sup>1</sup> and ASME Section VIII Steam, (English, lb/h) Flow Coefficient = 0.878								
Set Pressure (psig)	Orifice, Area in <sup>2</sup>							
	J (1.414)	K (2.022)	L (3.138)	M (3.960)	N (4.774)	P (7.018)	Q (12.155)	R (17.600)
10	1775	2538	3938	4970	5991	8807	15254	22087
15	2091	2990	4640	5855	7059	10377	17972	26023
20	2410	3447	5349	6751	8138	11963	20720	30002
25	2730	3904	6059	7646	9217	13550	23468	33981
30	3050	4361	6768	8541	10297	15137	26217	37961
35	3401	4864	7549	9526	11484	16882	29239	42338
40	3753	5367	8329	10511	12671	18627	32262	46715
45	4105	5870	9109	11496	13859	20373	35285	51092
50	4456	6373	9890	12480	15046	22118	38308	55469
55	4808	6875	10670	13465	16233	23863	41331	59846
60	5160	7378	11451	14450	17420	25609	44354	64223
65	5511	7881	12231	15435	18608	27354	47377	68600
70	5863	8384	13011	16420	19795	29099	50399	72977
75	6215	8887	13792	17405	20982	30845	53422	77354
80	6566	9390	14572	18389	22169	32590	56445	81731
90	7270	10395	16133	20359	24544	36081	62491	90485
100	7973	11401	17694	22329	26918	39571	68537	99239
110	8676	12407	19255	24298	29293	43062	74582	107993
120	9380	13413	20815	26268	31668	46553	80628	116747
130	10083	14418	22376	28238	34042	50043	86674	125501
140	10786	15424	23937	30207	36417	53534	92720	134255
150	11489	16430	25498	32177	38791	57025	98765	143009
160	12193	17435	27059	34147	41166	60515	104811	151763
170	12896	18441	28619	36116	43540	64006	110857	160517
180	13599	19447	30180	38086	45915	67497	116903	169271
190	14303	20453	31741	40056	48289	70987	122948	178025
200	15006	21458	33302	42025	50664	74478	128994	186779
210	15709	22464	34863	43995	53038	77969	135040	195533
220	16413	23470	36423	45965	55413	81459	141086	204287
230	17116	24475	37984	47934	57787	84950	147131	213041
240	17819	25481	39545	49904	60162	88441	153177	221795
250	18523	26487	41106	51873	62536	91931	159223	230549

#### Note

1. No code stamp or 'NB' on nameplate below 15 psig set.

## Models 6252 and 6254

### Capacities for Model 6254

ASME Section IV Steam, (lb/h) [kg/h]						
Set Pressure	Orifice, Area in <sup>2</sup> [cm <sup>2</sup> ]					
	J	K	L	M	N	P
(psig)	1.414	2.022	3.138	3.960	4.774	7.018
[barg]	[9.123]	[13.045]	[20.245]	[25.548]	[30.800]	[45.277]
15	2215	3168	4916	6204	7479	10994
[1.0]	[1003]	[1435]	[2227]	[2810]	[3388]	[4980]

### Order Information - Models 6252 and 6254

**Model Number/Order Guide**

**Model Number Position**

1	2	3	4	5	6	7	8	9	10	11	12	13	14	15	16
---	---	---	---	---	---	---	---	---	----	----	----	----	----	----	----

**Example**

6	2	5	2	F	L	K	0	1	-	A	S	0	0	2	0
---	---	---	---	---	---	---	---	---	---	---	---	---	---	---	---

**Model**

6252  
6254

**Connection Model**

A - Female x Female  
F - 250# Flange x Female  
K - 250# Flange x 125# Flange

**Orifice**

J	N
K	P
L	Q
M	R

**Inlet Size**

G - 1 1/2-inch [38.1]	K - 3-inch [76.2]
H - 2-inch [50.8]	M - 4-inch [101.6]
J - 2 1/2-inch [63.5]	P - 6-inch [152.4]

**Variation (01 through 99)**

01 - Plain lever  
02 - Plain lever with gag

**Design Revision**

Indicates non-interchangeable revision.  
Dash (-) if original design.

**Valve Service**

A - Steam ASME Section I (Model 6252 only)  
G - Steam ASME Section IV (Model 6254 (15 psig) [1.0 barg] only)  
K - Air ASME Section VIII (Model 6252 only)  
L - Steam ASME Section VIII (Model 6252 only)  
N - Non-code Air/Gas  
P - Non-code Steam

**Spring Material**

S - Steel (plated)

**Set Pressure**

Model 6252 - 10 psig [0.34 barg] (0005) through 250 psig [17.2 barg] (0250)  
Model 6254 - 15 psig [1.0 barg] (0015)

