

SUBMITTAL DATA

4" DIA. STEAM TO WATER

U-TUBE HEAT EXCHANGER

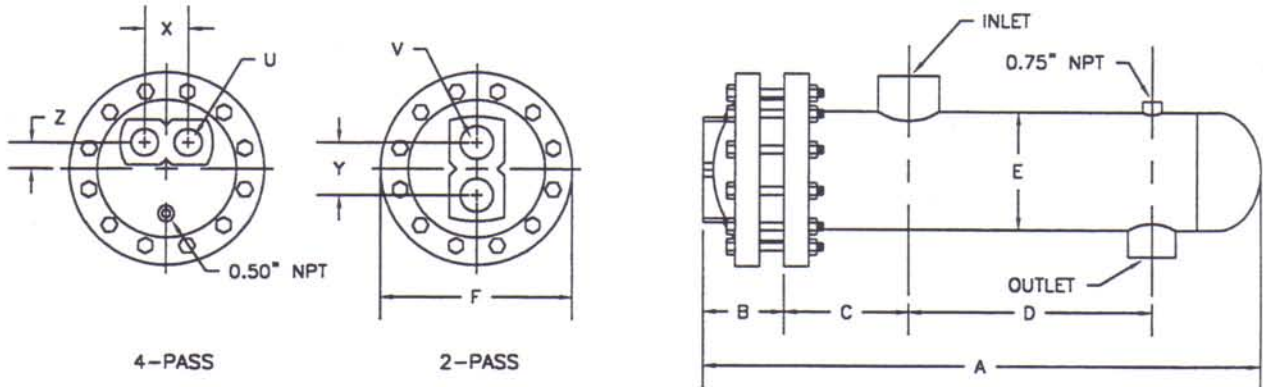

MODEL NO.	HEAT EXCHANGER								2 PASS			4 PASS			
	A	B	C	D	E	F	INLET	OUTLET	Y	V	SQ. FT.	X	Z	U	SQ. FT.
S424(*)A	28.60	2.72	5.00	14.75	4.50	9.00	2" NPT	1" NPT	2.62	1.25" NPT	3.19	2.00	1.00	1" NPT	3.19
S436(*)A	40.60			26.75							4.79				4.79
S448(*)A	52.60			38.75							6.39				6.39
S460(*)A	64.60			50.75							7.98				7.98
S472(*)A	76.60			62.75							9.58				9.58
S484(*)A	88.60			74.75							11.18				11.18
S496(*)A	100.60			86.75							12.77				12.77
S4108(*)A	112.60			98.75							14.37				14.37
S4120(*)A	124.60			110.75							15.97				15.97

(*) INSERT NUMBER OF PASSES.

MATERIALS OF CONSTRUCTION

PART	MATERIAL
HEAD	CAST IRON
SHELL	STEEL
TUBE SHEET	STEEL
TUBING	3/4" O.D. COPPER
BAFFLES	STEEL
CAGE MATERIAL	STEEL

DESIGNED & CONSTRUCTED PER ASME SECT VIII DIV 1

MAXIMUM OPERATING CONDITIONS

TUBE SIDE WORKING PRESSURE	150 PSI
SHELL SIDE WORKING PRESSURE	150 PSI
HYDROSTATIC TEST PRESSURE TUBE SIDE	300 PSI
HYDROSTATIC TEST PRESSURE SHELL SIDE	225 PSI
MAXIMUM TEMPERATURE TUBE SIDE	375°F
MAXIMUM TEMPERATURE SHELL SIDE	375°F

JOB NAME _____
 LOCATION _____
 ENGINEER _____
 CONTRACTOR _____
 SALES REP. _____

S4CLDWG REV: A

MODEL NO. ORDERED

STEAM PRESSURE	
ENT TEMP.	LEAV TEMP
TUBE SIDE FLOW	LIQUID
FOULING FACTOR	SQ FT
TUBE SIDE PRESSURE DROP	FT
VELOCITY	FT/SEC