

## SUBMITTAL DATA

### 12" DIA. STEAM TO WATER

### U-TUBE HEAT EXCHANGER

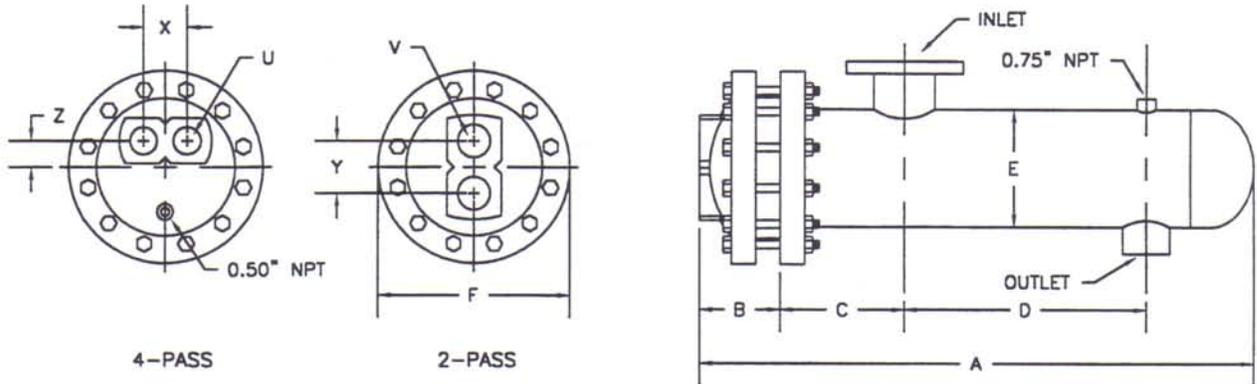

MODEL NO.	HEAT EXCHANGER								2 PASS		4 PASS				
	A	B	C	D	E	F	INLET	OUTLET	Y	V	SQ. FT.	X	Z	U	SQ. FT.
S1224(*)A	33.69			8.75							41				38
S1236(*)A	45.69			20.75							62				59
S1248(*)A	57.69			32.75			6" FLG	2" NPT			84				80
S1260(*)A	69.69			44.75							106				100
S1272(*)A	81.69	4.31	10.00	56.75	12.75	19.00			6.38	4"*** NPT	128	5.00	2.75	3" NPT	121
S1284(*)A	93.69			68.75							150				142
S1296(*)A	105.69			80.75			8" FLG	2.5" NPT			172				163
S12108(*)A	117.69			92.75							194				183
S12120(*)A	129.69			104.75							216				204

(\*) INSERT NUMBER OF PASSES.

\*\* 4" NPT @ 125 PSI TUBE SIDE WORKING PRESSURE STANDARD.  
3" NPT @ 150 PSI TUBE SIDE WORKING PRESSURE OPTIONAL.

DESIGNED & CONSTRUCTED PER ASME SECT VIII DIV 1

#### MATERIALS OF CONSTRUCTION

PART	MATERIAL
HEAD	CAST IRON
SHELL	STEEL
TUBE SHEET	STEEL
TUBING	3/4" O.D. COPPER
BAFFLES	STEEL
CAGE MATERIAL	STEEL

#### MAXIMUM OPERATING CONDITIONS

	2-PASS 4" NPT	2-PASS 3" NPT	4-PASS 3" NPT
TUBE SIDE WORKING PRESSURE	125 PSI	150 PSI	150 PSI
SHELL SIDE WORKING PRESSURE	150 PSI	150 PSI	150 PSI
HYDROSTATIC TEST PRESSURE TUBE SIDE	250 PSI	300 PSI	300 PSI
HYDROSTATIC TEST PRESSURE SHELL SIDE	225 PSI	225 PSI	225 PSI
MAXIMUM TEMPERATURE TUBE SIDE	375°F	375°F	375°F
MAXIMUM TEMPERATURE SHELL SIDE	375°F	375°F	375°F

JOB NAME \_\_\_\_\_  
 LOCATION \_\_\_\_\_  
 ENGINEER \_\_\_\_\_  
 CONTRACTOR \_\_\_\_\_  
 SALES REP. \_\_\_\_\_

#### MODEL NO. ORDERED

STEAM PRESSURE	
ENT TEMP.	LEAV TEMP
TUBE SIDE FLOW	LIQUID
FOULING FACTOR	SQ FT
TUBE SIDE PRESSURE DROP	FT VELOCITY FT/SEC