



## Series 6000

ASME Section I and VIII, Steam, 'V' and 'UV', ASME Section VIII, Air/Gas 'UV' National Board Certified. Models 6933, 6934, and 6935 are ASME Section IV, 'Steam', 'HV' National Board Certified. PED Certified for Non-Hazardous Gas.

### Features

- **O-ring seats available** for exceptional leak-free performance, reduced maintenance cost, multiple cycles with tight shutoff, improved seating integrity.
- **Wide hex on valve nozzle** provides wrenching service clearance for easy installation.
- **Dual control rings offer easy adjustability** for precise opening with minimum preopen or simmer and exact blowdown control.
- **Pivot between disc and spring** corrects misalignment and compensates for spring side thrust.
- **Grooved piston model disc** reduces sliding area and friction.

### Model Descriptions

**Model 6010:** Side outlet. Full nozzle design with bronze/brass trim. Available with O-ring seats. For exceptional leak-free performance.

**Model 6021:** Same as Model 6010 with Teflon® (PFA) disc insert. For exceptional leak-free performance (use on steam only).

**Model 6030:** Same as Model 6010 except SS trim (nozzle and disc). Available with O-ring seats for exceptional leak-free performance.

**Model 6182:** Top outlet. Full nozzle design with bronze/brass trim. O-ring seat available for exceptional leak-free performance.

**Model 6121:** Same as Model 6182 with Teflon® (PFA) disc insert. For exceptional non-leak performance (use on steam only).

**Model 6130:** Same as Model 6182 except SS trim (nozzle and disc). O-ring seat available for exceptional leak-free performance.

**Model 6186:** Top outlet. Full nozzle design with bronze/brass trim. 150 psig [10.3 barg] maximum set pressure. Replaces Model 86 (original equipment only).

**Model 6283:** Over-sized side outlet. Full nozzle design bronze/brass trim.

**Model 6221:** Same as Model 6283 with Teflon® (PFA) disc insert. For exceptional leak-free performance (use on steam only).

**Model 6230:** Same as Model 6283 except SS trim (nozzle and disc).

**Model 6933:** Same as Model 6010 except certified for ASME code Section IV. Low pressure steam heating boilers set at 15 psig [1.0 barg] only.

**Model 6934:** Same as Model 6021 except certified for ASME code Section IV. Low pressure steam heating boilers set at 15 psig [1.0 barg] only.

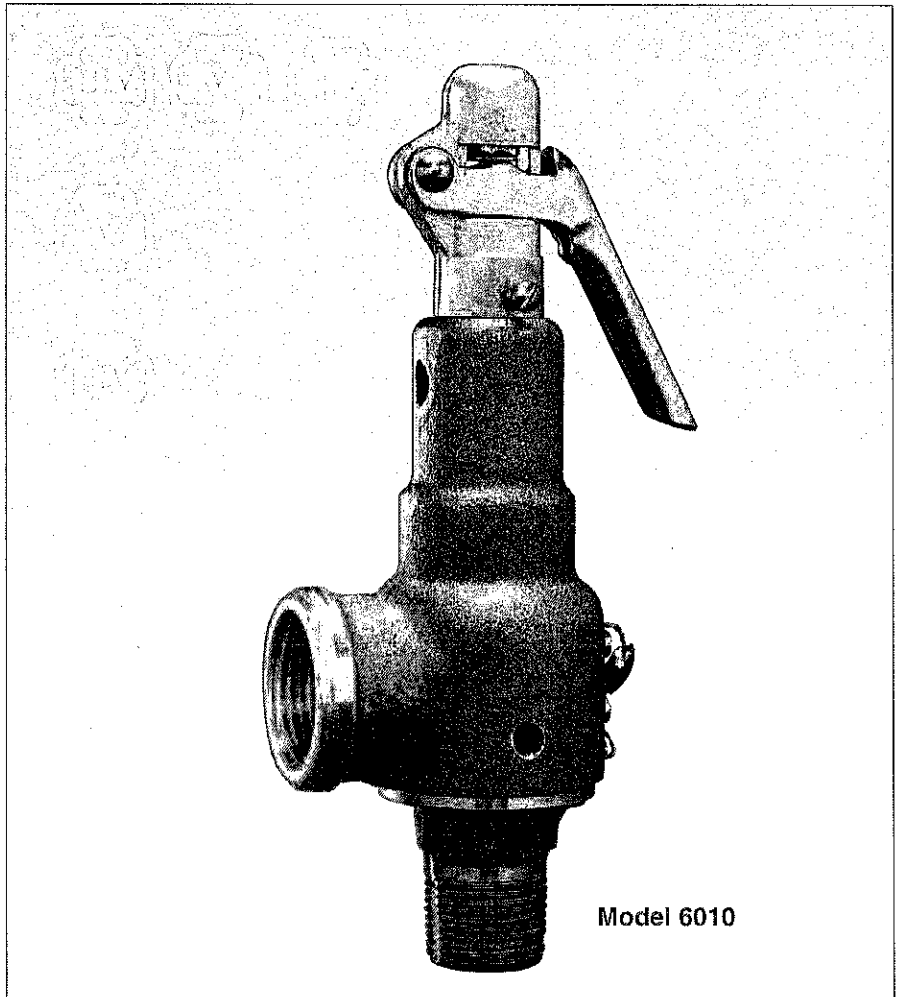

Model 6010

**Model 6935:** Same as Model 6030 except certified for ASME code Section IV. Low pressure steam heating boilers set at 15 psig [1.0 barg] only.

### Applications

- Steam Boilers and Generators.
- Air/Gas Compressors - reciprocating or rotary - portable or stationary, intercoolers and aftercoolers.
- Pressure Vessels - containing steam, air or non-hazardous gas. Including tanks, receivers, sterilizers and autoclaves.
- Pressure Reducing Stations - protection of the discharge or low pressure side of system.

### Pressure and Temperature Limits

**Models 6010, 6021, 6182, 6283, 6221**

#### Steam Service

3 to 250 psig [0.2 to 17.2 barg]  
-60° to 406°F [-51° to 208°C]

#### Air/Gas Service

3 to 300 psig [0.2 to 20.7 barg]  
-60° to 406°F [-51° to 208°C]

#### Models 6030, 6130, 6230

#### Steam and Air/Gas Service

3 to 300 psig [0.2 to 20.7 barg]  
-60° to 425°F [-51° to 218°C]

### Notes

1. Resilient seats determine temperature range. (see page 11)
2. Teflon® is a registered trademark of E.I. du Pont de Nemours Company.

Kunkle is either a trademark or registered trademark of Tyco International Services AG or its affiliates in the United States and/or other countries. All other brand names, product names, or trademarks belong to their respective holders.

**Series 6000**

**Parts and Materials**

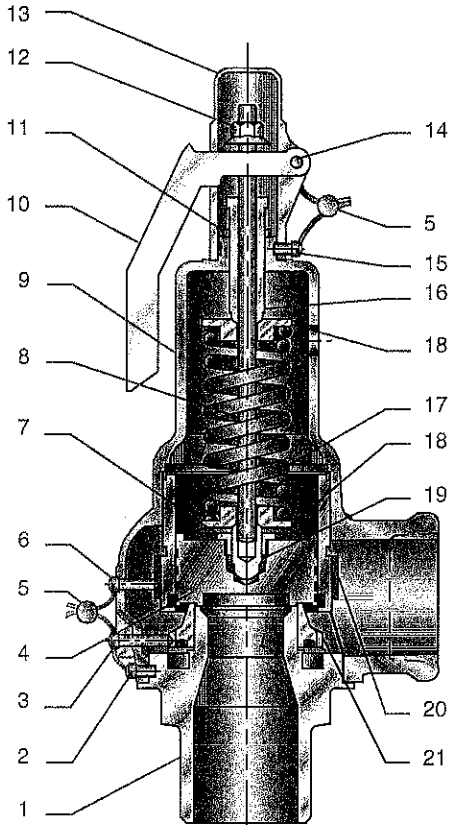

**Models 6010, 6030, 6283,  
6230, 6933, 6935**

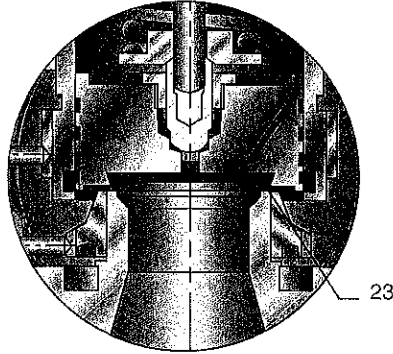

**Models 6121, 6221, 6934  
Teflon® Seat Configuration**

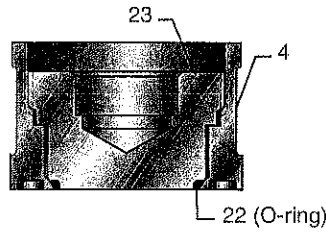

**Models 6010, 6030, 6283,  
6230, 6933, 6935  
Optional Soft Seat**

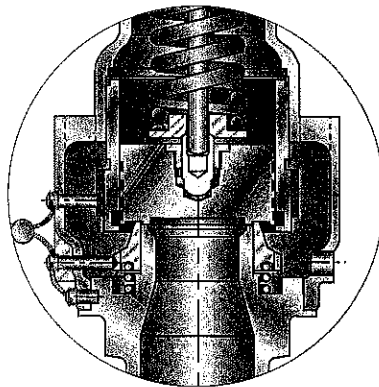

**Models 6182, 6121, 6130, 6186  
Top Outlet Configuration**



## Series 6000

Parts and Materials		
No.	Part Name	Materials
1	Nozzle	BRS B283-C48500 for D Orifice <sup>3</sup> BRZ SB62 for E thru J Orifice <sup>3</sup>
2	Body Set Screw	SS 18-8
3	Warn Ring Set Screw	SS 18-8
4	Disc	B21 C48500 <sup>4</sup>
5	Wire and Seal	SS Wire and Lead Seal
6	Guide Set Screw	SS 18-8
7	Retainer Nut <sup>2</sup>	Brass B16
8	Stem	SS, A582 TY416
9	Body	BRZ B584-C84400
10	Lever	STL A109 or JIS SPCC Equivalent/ZN Plated Yellow
11	Jam Nut	Brass B16
12	Lift Nut	STL A108-1018/ZN Plated
13	Cap	BRS B176 Alloy 230A
14	Lever Pin	STL A108-12L14
15	Cap Set Screw	SS 18-8
16	Compression Screw	BRS B16
17	Spring	ASTM A-313 TY 631
18	Spring Step	BRS B16
19	Stem Retainer	BRS B16
20	Guide	BRS B16 for D and E Orifice BRZ B584-C84400 for F thru J Orifice
21	Warn Ring	BRS B16
22	Seat	<i>Note 1</i>
23	Seat Retainer	BRS B16 <sup>5</sup>

### NOTES:

- Models 6021, 6121, 6221 and 6934 Teflon®, optional O-ring seat available for all others except Models 6933 and 6935.
- Section IV only.
- Models 6030, 6130, 6230 and 6935 are SS SA351-CF8.
- Models 6030, 6130, 6230 and 6935 are SS SA479-304 (D thru H Orifice) or SS SA479-316 (J Orifice).
- Models 6030, 6130 and 6230 are SS SA479-304.



# Series 6000

Series 6000 and Models 6933-6935 ASME Section I and VIII, Steam, ASME Section VIII, Air/Gas National Board Certified. Models 6933-6935 are ASME Section IV, 'Steam,' National Board Certified

Specifications										
Model Number <sup>1</sup>	Orifice	Connections				Valve Dimensions			Approximate Weight	
		ANSI Standard		ANSI Standard		A	B	C		
		Inlet	Outlet	Inlet	Outlet					
in [mm]	in [mm]	in [mm]	in [mm]				lb [kg]			
60**DC#	D	1/2 [12.7]	3/4 [19.0]	2 1/8 [54]	1 5/8 [41]	6 1/2 [165]	11 1/2 [0.7]			
60**DD# <sup>2</sup>	D	3/4 [19.0]	3/4 [19.0]	2 1/8 [54]	1 5/8 [41]	6 1/2 [165]	13 1/4 [0.8]			
61**DC#	D	1/2 [12.7]	—	—	—	6 1/2 [165]	11 1/4 [0.6]			
60**ED#	E	3/4 [19.0]	1 [25.4]	2 3/8 [60]	1 3/4 [44]	7 1/2 [191]	21 1/2 [1.1]			
60**EE# <sup>2</sup>	E	1 [25.4]	1 [25.4]	2 1/2 [64]	1 3/4 [44]	7 5/8 [194]	23 1/4 [1.2]			
61**ED#	E	3/4 [19.0]	—	—	—	7 1/2 [191]	21 1/4 [1.0]			
62**ED#	E	3/4 [19.0]	1 1/4 [31.75]	2 7/8 [73]	1 3/4 [44]	7 1/2 [191]	23 1/4 [1.2]			
60**FE#	F	1 [25.4]	1 1/4 [31.8]	2 5/8 [67]	2 [51]	8 1/2 [216]	31 1/2 [1.6]			
60**FF# <sup>2</sup>	F	1 1/4 [31.8]	1 1/4 [31.8]	2 7/8 [73]	2 [51]	8 3/4 [222]	33 1/4 [1.7]			
61**FE#	F	1 [25.4]	—	—	—	8 1/2 [222]	31 1/4 [1.5]			
62**FE#	F	1 [25.4]	1 1/2 [38.0]	2 7/8 [73]	2 [51]	8 1/2 [222]	33 1/4 [1.7]			
60**GF#	G	1 1/4 [31.8]	1 1/2 [38.0]	3 1/8 [79]	2 3/8 [60]	9 5/8 [244]	51 1/2 [2.5]			
60**GG# <sup>2</sup>	G	1 1/2 [38.0]	1 1/2 [38.0]	3 3/8 [86]	2 3/8 [60]	10 [254]	53 1/4 [2.6]			
61**GF#	G	1 1/4 [31.8]	—	—	—	9 5/8 [244]	5 [2.3]			
62**GF#	G	1 1/4 [31.8]	2 [51.0]	3 3/8 [86]	2 1/4 [57]	9 5/8 [244]	53 1/4 [2.6]			
60**HG#	H	1 1/2 [38.0]	2 [51.0]	3 5/8 [92]	2 3/4 [70]	10 5/8 [270]	73 1/4 [3.5]			
60**HH# <sup>2</sup>	H	2 [51.0]	2 [51.0]	4 1/8 [105]	2 3/4 [70]	11 1/8 [283]	8 [3.6]			
61**HG#	H	1 1/2 [38.0]	—	—	—	10 5/8 [270]	71 1/4 [3.3]			
62**HG#	H	1 1/2 [38.0]	2 1/2 [64.0]	3 7/8 [98]	3 [76]	10 5/8 [270]	8 [3.6]			
60**JH#	J	2 [51.0]	2 1/2 [64.0]	4 1/4 [108]	3 3/8 [86]	13 5/8 [346]	15 1/2 [7.0]			
60**JJ# <sup>2</sup>	J	2 1/2 [64.0]	2 1/2 [64.0]	4 1/2 [114]	3 3/8 [86]	14 [356]	15 3/4 [7.2]			
61**JH#	J	2 [51.0]	—	—	—	13 5/8 [346]	15 [6.8]			
62**JH#	J	2 [51.0]	3 [76.0]	4 5/8 [117]	3 3/8 [86]	13 5/8 [345]	15 1/2 [7.0]			

### Notes

1. Replace asterisks with desired model number. Replace # with desired seat material.
2. Model 6030 available only 1/2 x 3/4-inch [12.7 x 19 mm], 3/4 x 1-inch [19 x 25.4 mm], 1 x 1 1/4-inch [25.4 x 31.8 mm], 1 1/4 x 1 1/2-inch [31.8 x 38 mm], 1 1/2 x 2-inch [38 x 51 mm] and 2 x 2 1/2-inch [51 x 64 mm].
3. Models 6933, 6934 and 6935 have same dimensions as Model 6010.

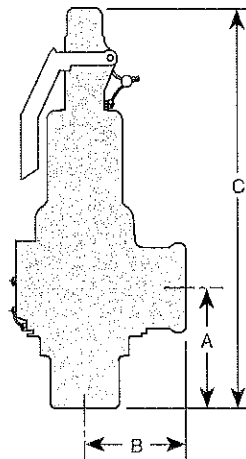

# Series 6000

## Capacities

**Note**

1. No code stamp or 'NB' on nameplate below 15 psig set.

**Non-coder and ASME Section VIII Steam (English, lb/m)**

Set Pressure (psig)	Orifice Area, in <sup>2</sup>					
	D (0.121)	E (0.216)	F (0.338)	G (0.554)	H (0.863)	J (1.414)
3	87	155	243	398	621	1017
4	100	178	279	457	711	1166
6	121	215	337	552	860	1409
8	137	245	384	629	980	1606
10	152	271	424	695	1083	1775
15	179	319	500	819	1276	2091
20	206	368	576	944	1471	2410
25	234	417	653	1070	1666	2730
30	261	466	729	1195	1861	3050
35	291	520	813	1333	2076	3401
40	321	573	897	1470	2291	3753
45	351	627	981	1608	2505	4105
50	381	681	1065	1746	2720	4456
55	411	734	1149	1884	2934	4808
60	442	788	1233	2022	3149	5160
65	472	842	1317	2159	3364	5511
70	502	896	1401	2297	3578	5863
75	532	949	1486	2435	3793	6215
80	562	1003	1570	2573	4008	6566
85	592	1057	1654	2710	4222	6918
90	622	1110	1738	2848	4437	7270
95	652	1164	1822	2986	4651	7621
100	682	1218	1906	3124	4866	7973
105	712	1272	1990	3262	5081	8325
110	742	1325	2074	3399	5295	8676
115	773	1379	2158	3537	5510	9028
120	803	1433	2242	3675	5725	9380
125	833	1487	2326	3813	5939	9731
130	863	1540	2410	3950	6154	10083
135	893	1594	2494	4088	6368	10434
140	923	1648	2578	4226	6583	10786
145	953	1701	2662	4364	6798	11138
150	983	1755	2746	4502	7012	11489
160	1043	1863	2915	4777	7442	12193
170	1104	1970	3083	5053	7871	12896
180	1164	2077	3251	5328	8300	13599
190	1224	2185	3419	5604	8729	14303
200	1284	2292	3587	5879	9159	15006
210	1344	2400	3755	6155	9588	15709
220	1404	2507	3923	6430	10017	16413
230	1465	2615	4091	6706	10446	17116
240	1525	2722	4259	6981	10876	17819
250	1585	2829	4428	7257	11305	18523
260	1645	2937	4596	7533	11734	19226
270	1705	3044	4764	7808	12163	19929
280	1766	3152	4932	8084	12592	20632
290	1826	3259	5100	8359	13022	21336
300	1886	3367	5268	8635	13451	22039



# Series 6000

## Capacities

ASME Section I Steam (English, lb/h)						
Set Pressure (psig)	Orifice Area, in <sup>2</sup>					
	D (0.121)	E (0.216)	F (0.338)	G (0.554)	H (0.863)	J (1.414)
15	173	309	484	793	1236	2025
20	201	358	560	918	1431	2344
25	228	407	637	1044	1626	2664
30	255	456	713	1169	1821	2983
35	283	504	789	1294	2015	3302
40	310	553	866	1419	2210	3622
45	337	602	942	1544	2405	3941
50	365	651	1018	1669	2600	4260
55	392	700	1095	1794	2795	4580
60	419	748	1171	1919	2990	4899
65	447	797	1247	2045	3185	5219
70	474	847	1325	2172	3384	5544
75	503	897	1404	2301	3585	5873
80	531	947	1483	2430	3785	6202
85	559	998	1561	2559	3986	6531
90	587	1048	1640	2688	4187	6860
95	615	1098	1718	2817	4388	7189
100	643	1148	1797	2946	4588	7518
105	671	1199	1876	3074	4789	7847
110	700	1249	1954	3203	4990	8176
115	728	1299	2033	3332	5191	8505
120	756	1349	2112	3461	5392	8834
125	784	1400	2190	3590	5592	9163
130	812	1450	2269	3719	5793	9492
135	840	1500	2348	3848	5994	9821
140	869	1550	2426	3977	6195	10150
145	897	1601	2505	4105	6395	10479
150	925	1651	2583	4234	6596	10808
160	981	1751	2741	4492	6998	11466
170	1037	1852	2898	4750	7399	12123
180	1094	1952	3055	5008	7801	12781
190	1150	2053	3212	5265	8202	13439
200	1206	2153	3370	5523	8604	14097
210	1263	2254	3527	5781	9005	14755
220	1319	2354	3684	6039	9407	15413
230	1375	2455	3842	6297	9808	16071
240	1432	2555	3999	6554	10210	16729
250	1488	2656	4156	6812	10612	17387
260	1544	2756	4313	7070	11013	18045
270	1600	2857	4471	7328	11415	18703
280	1657	2957	4628	7585	11816	19360
290	1713	3058	4785	7843	12218	20018
300	1769	3158	4942	8101	12619	20676



# Series 6000

## Specifications

### Service Recommendations for Resilient Seat/Seal Materials

Seat/Seal Materials	Service Recommendation
Viton® A (-10 to 406°F) [-23 to 208°C]	Air and Gas
Ethylene Propylene (-70 to 400°F) [-57 to 205°C]	Steam

ASME Section I and VIII, Steam, ASME Section VIII, Air/Gas National Board Certified. Models 6930, 6933, 6935 ASME Section IV, National Board Certified

### Model Number/Order Guide

<b>Model Number Position</b>	1	2	3	4	5	6	7	7	8	9	10	11	12	13	14	15
<b>Example</b>	6	0	1	0	H	G	M	0	1	-	A	M	0	1	5	0

**Model**

6010	6130	6230
6021	6186	6933
6030	6283	6934
6182	6221	6935
6121		

**Orifice**

D	G
E	H
F	J

**Inlet Size**

C - 1/2-inch [12.7]	G - 1 1/2-inch [38.1]
D - 3/4-inch [19.0]	H - 2-inch [50.8]
E - 1-inch [25.4]	J - 2 1/2-inch [63.5]
F - 1 1/4-inch [31.8]	

**Seat Material**

- M - Metal
- E - EPR
- V - Viton®

**Variation (01 through 99)**

- 01 - Plain lever
- 02 - Plain lever with vibration dampener
- 03 - Plain lever with gag
- 60 - BSP Threads

**Design Revision**  
Indicates non-interchangeable revision. Dash (-) if original design.

**Valve Service**

- A - Steam ASME Section I
- K - Air/Gas ASME Section VIII
- L - Steam ASME Section VIII
- G - Steam ASME Section IV (Models 6933, 6934, 6935 only)
- P - Steam, Non-code
- N - Air, Non-code

**Spring Material**

- M - SS

**Set Pressure**

0015 - 15 psig [1.0 barg] only for Models 6933, 6934, 6935

