

MODEL TH750V-6 [REDACTED] -SWEN

NOZZLES & CONNECTIONS		
MODEL	624/636/648	
ITEM	SIZE, TYPE	SERVICE
A	2" NPT	COLD WATER INLET
B	2" NPT	HOT WATER OUTLET
C	SEE TH750-SIZING CHART	CONTROL VALVE INLET
D	SEE ITEM 5	CONDENSATE OUTLET
E	1" NPT	P & T RELIEF
F	.75 NPT	HIGH TEMP SOLENOID VLV.
G	1" NPT	DRAIN
H	.75 NPT	TEMPERATURE GAUGE

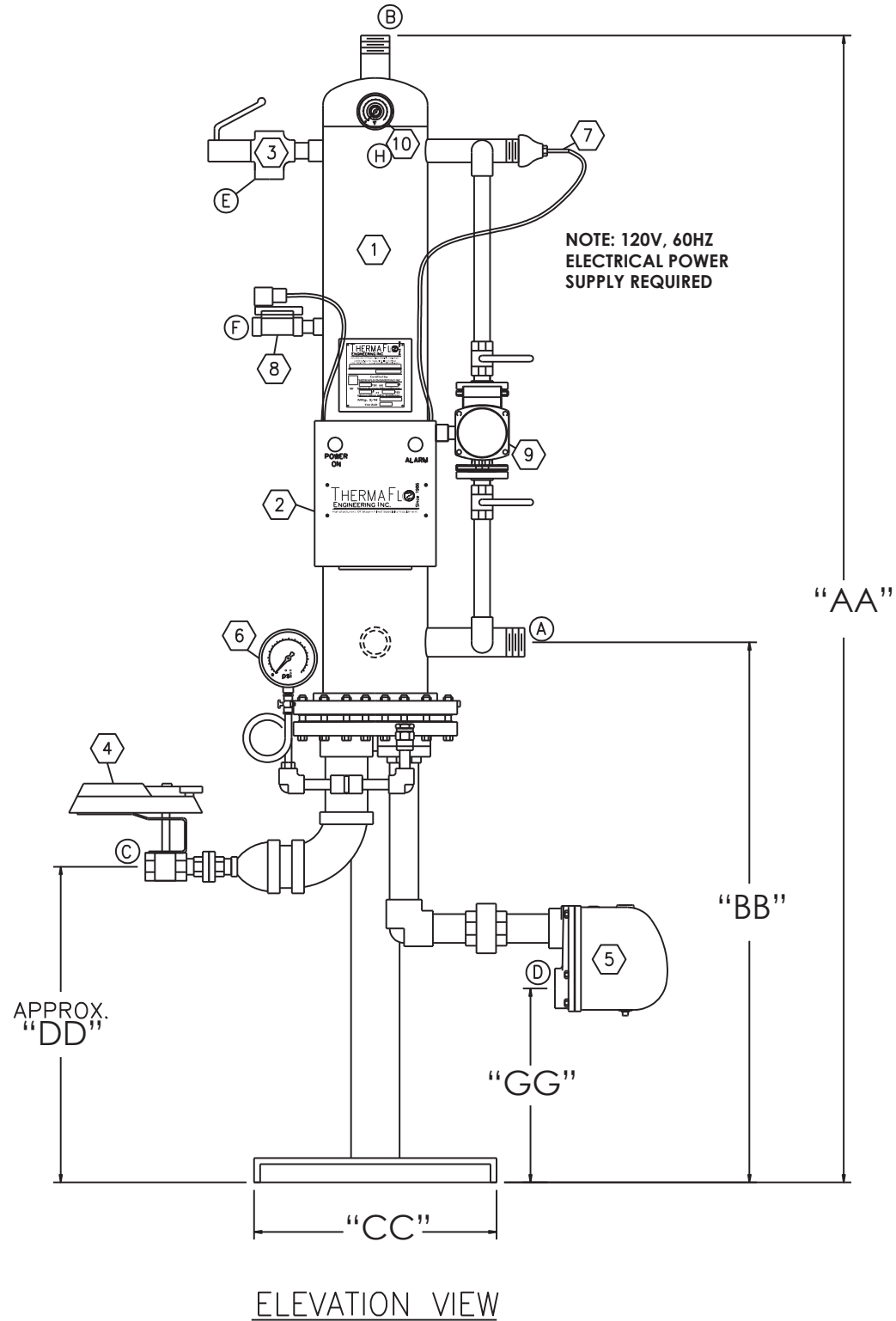
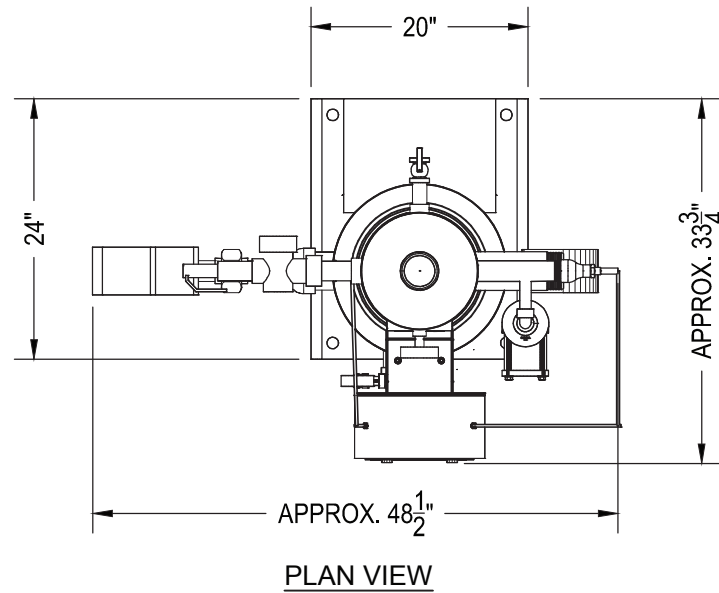

BILL OF MATERIAL	
ITEM	DESCRIPTION
1	Thermaflo 316L SS ASME CODE STAMPED SHELL, SINGLE WALL, TUBE BUNDLE, CAST IRON 2-PASS STEAM HEAD
2	THERMAFLO ENGINEERING INC. EC-800-EN-PM6 ELECTRONIC CONTROL PANEL. UL LISTED, NEMA 4 ENCLOSURE, WITH PID ELECTRONIC TEMPERATURE CONTROLLER, SAFETY SHUTDOWN SYSTEM, WHITE POWER ON AND RED OVER TEMPERATURE LIGHTS.
3	CASH ACME PRESSURE AND TEMPERATURE RELIEF VALVE, SET @ 150 PSIG @ 210°F
4	TYPE BV SERIES ELECTRONIC SYSTEM CONTROL VALVE, ELECTRONIC MODULATING ACTUATOR, FAIL CLOSED.
5	FLOAT AND THERMOSTATIC STEAM TRAP
6	4 1/2 DIAL SS COMPOUND PRESSURE GAUGE 30"-0-30 PSIG 1/4" LOWER MOUNT W/SYPHON, ISOLATION VALVE AND VACUUM BREAKER.
7	1/2" RTD WITH 4-20MA INPUT TO THE CONTROLLER
8	3/4" HIGH TEMP DUMP SOLENOID VALVE NORMALLY CLOSED/FAIL CLOSED
9	TACO 009-IFC STAINLESS STEEL CIRCULATION PUMP
10	3" DIAL BIMETAL THERMOMETER 0-250°F RANGE WITH STAINLESS STEEL WELL

DESIGN DATA	
ASME CODE SECTION VIII, DIV 1 STAMP UM	
SHELL RATED AT 150 PSIG @ 375°F TUBES RATED AT 150 PSIG @ 375°F	
MATERIALS OF CONSTRUCTION	
SHELL	316L STAINLESS STEEL
TUBESHEET	304 SS
TUBES	COPPER .035 WALL 3/4" OD
STEAM HEAD	CLOSE GRAIN CAST IRON

- TAG:** [REDACTED]
- ASME CODE SECTION VIII DIV.1 UM STAMP CONSTRUCTION
 - 100% FACTORY STEAM TESTED BEFORE SHIPMENT
 - SINGLE SEATED CONTROL VALVE FOR DEAD TIGHT SHUT OFF ON NO LOAD CONDITIONS
 - VERTICAL CROSS FLOW SELF CLEANING TUBE DESIGN
 - 316L STAINLESS STEEL SHELL CONSTRUCTION
 - FULL SELF TUNING PID DIGITAL CONTROLS
 - DOUBLE SAFETY SOLENOID SAFETY HIGH LIMIT SYSTEM FAIL SAFE TEMPERATURE CONTROLLER AND CONTROL VALVE
 - SHELL BLOWDOWN VALVE AND EXPANDABLE TUBE DESIGN TO REMOVE INTERNAL SCALE BUILDUP
 - 2" THICK INSULATION AIR GLASS & VINYL JACKET
 - ALL DIMENSIONS TO HAVE ±1/2" TOLERANCE
 - MOUNTING FRAME HAMMERTONE POWDER COATED

- NOTE: 1. MASTER BLEND VALVES SHOULD ALWAYS BE USED ON DOMESTIC WATER SYSTEMS TO PREVENT ANY CHANCE OF SCALDING.
2. PIPE ITEMS 3,8 AND SHELL DRAIN "G" TO SUITABLE FLOOR DRAIN.
3. NOZZLES WILL NOT SUPPORT EXTERNAL LOADINGS.
4. TANK & PIPING TO BE FULLY SUPPORTED IN FIELD.
5. CONTROL VALVE AND FT TRAP SHIPPED LOOSE FOR FIELD REINSTALL AFTER FACTORY TEST

Manufacturers Of Steam Fired Specialty Equipment
 12249 Nations Ford Road, Pineville NC 28134
 (704) 940-1228 www.thermafloengineering.com

DESCRIPTION: TH750V-6 [REDACTED] -SWEN STEAM FIRED WATER HEATER		
CUSTOMER: [REDACTED]		
J.O. # [REDACTED]	QTY. [REDACTED]	DATE: [REDACTED]
SCALE: 1=1 PRINTED: NTS	DR. NAL	P.O. # [REDACTED]
SALES: [REDACTED]	DRAWING # TH750V-6 [REDACTED] -SWEN	REV. [REDACTED]

STANDARD DIMENSIONS STEAM / WATER									
MODEL #								WEIGHT (lbs)	
TH750V	"AA"	"BB"	"CC"	"DD"	"EE"	"FF"	"GG"	DRY	WET
624	95"	44"	20"	26"	24"	36"	16"	495	545
636	95"	44"	20"	26"	24"	36"	16"	520	525
648	107"	56"	20"	39"	24"	36"	28"	555	565

CONDITIONS OF SERVICE:

DOMESTIC WATER FLOW: [REDACTED] GPM
 INLET TEMP: [REDACTED] F°
 OUTLET TEMP: [REDACTED] F°
 INLET STEAM PRESSURE TO CONTROL VALVE [REDACTED] PSIG*
 STEAM CAPACITY REQUIRED: [REDACTED] LBS/HR

ITEM	CONNECTION	SIZE, TYPE, PN	SERVICE
3	E	[REDACTED]	P & T RELIEF
4	C	[REDACTED]	CONTROL VALVE
5	D	[REDACTED]	STEAM TRAP
[REDACTED]	[REDACTED]	[REDACTED]	[REDACTED]
[REDACTED]	[REDACTED]	[REDACTED]	[REDACTED]

* NOTE: INLET PSIG OVER 50# REQUIRES H.P. OPTION