

## TYPE P PRESSURE REDUCING PILOT

DIMENSIONS: Inches

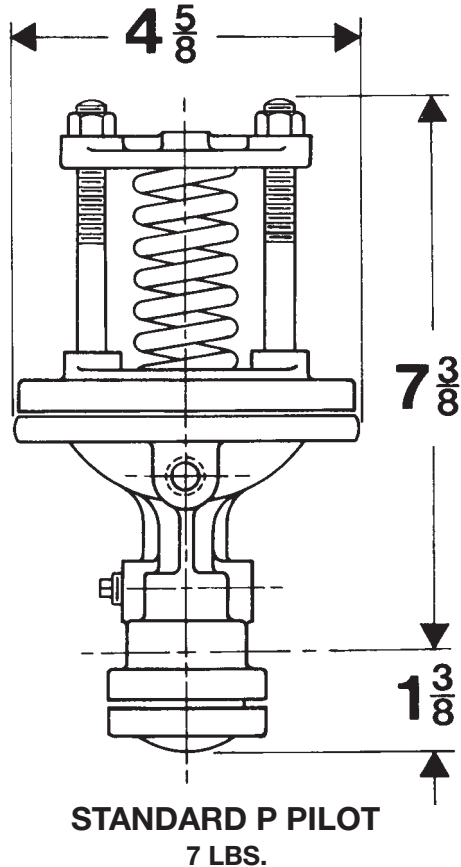

The combination of the P pilot and the PT balance trim value completes the Thermaflo Engineering type PT Pressure Regulating Valve.

The Type P pilot is spring loaded. Normal accuracy of regulation is  $\pm 1$  psi. The adjustable range of delivery pressure is governed by the choice of adjusting spring as shown in Table 1.

PRESSURE RANGE (PSIG)	ADJUSTING SPRING - Item 4		
	PART NUMBER	WIRE DIA. (Inch)	COLOR
3 - 20*	05-05007-00	3/16	Aluminum
5 - 50*	05-05003-00	1/4	Orange
10 - 100	05-05005-00	5/16	Green
20 - 150	05-05012-00	11/32	Black

\*With Vacuum Spring Assembly, minimum range is 30 inches Hg; maximum is reduced by 15 PSIG.

**TABLE 1**

### RATINGS (Maximum Inlet Conditions)

Construction	Pressure	(Temperature)
<input type="checkbox"/> Cast Iron .....	250 PSIG.....	(450°F)
<input type="checkbox"/> Cast Steel .....	600 PSIG.....	(750°F)

PRINTED IN U.S.A.

### OPTIONS

- Spring Chamber
- Adjusting Handwheel
- Wall Bracket
- Locking Device
- Composition Disc
- Integral Mount Body
- Vacuum Spring Assembly

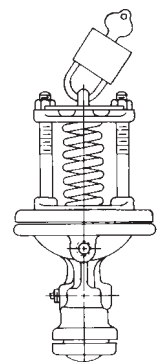
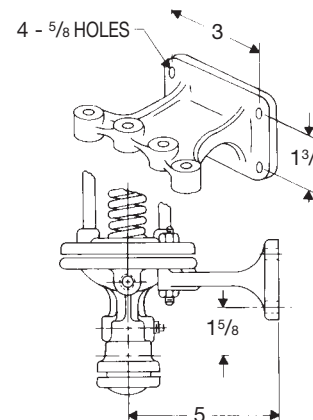
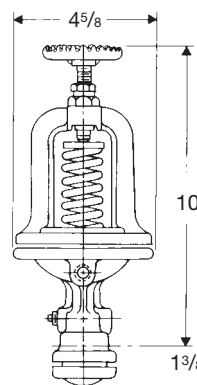
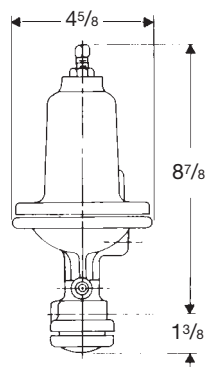

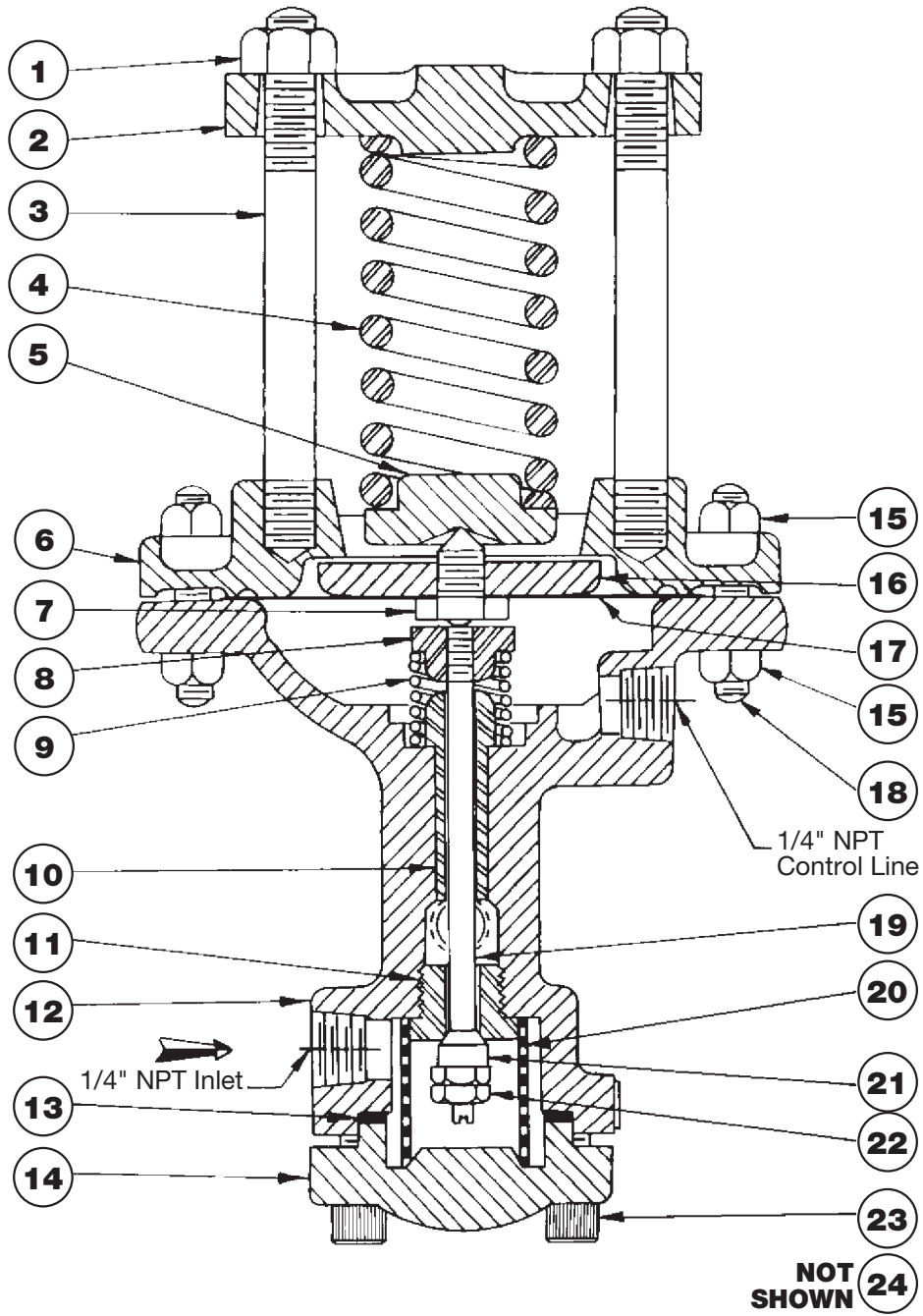

If no plate attached,  
serial number is  
stamped here

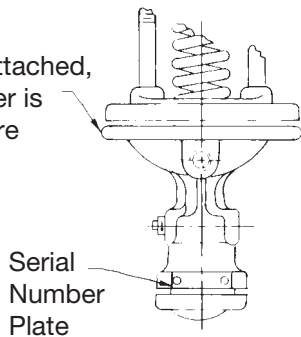

When ordering parts, it is essential that the pilot  
type, service and serial number be stated.

Select part by item number, but order by part  
number. Specify complete part number when  
ordering.

**TABLE 2**

ITEM NO.	PART NAME	MATERIAL	PART NO.	QTY.	REMARKS
1	Adjusting Nut	Steel	05-02874-00	2	
2	Spring Yoke	Iron	05-06183-00	1	
3	Standard	Steel	04-05219-00	2	
4	Adjusting Spring	Steel	See Table 1	1	
5	Spring Button	Steel	04-01040-00	1	
6	Cowl	Cast Iron	04-01508-00	1	Cast Iron Body
	Cowl	Steel	04-01592-00	1	Steel Body
7	Diaphragm Screw <sup>1</sup>	Steel	04-04822-00	1	
8	Pusher Plate <sup>1</sup>	Steel	04-03718-00	1	
9	Valve Spring <sup>1</sup>	Inconel	05-04985-00	1	
10	Bushing	St. Steel	04-01080-00	1	
11	Seat Ring <sup>1</sup>	Seco Metal	04-04057-90	1	
12	Body, Bushing, Plug	Cast Iron	07-03514-00	1	
	Body, Bushing, Plug	Steel	07-04267-02	1	
13	Gasket <sup>1</sup>	Blugard	05-02378-01	1	Cast Iron Body, Non-Asbestos
	Gasket <sup>1</sup>	Flexitalic	05-11718-00	1	Steel Body, Non-Asbestos
14	Blind Flange	Cast Iron	04-02151-00	1	
	Blind Flange	Steel	04-11678-00	1	
15	Diaphragm Nut	Steel	05-02871-00	12	Cast Iron Body
	Diaphragm Nut	Steel	05-02845-00	24	Steel Body
16	Pressure Plate <sup>1</sup>	Steel	04-03679-00	1	
17	Diaphragm <sup>1</sup>	St. Steel	04-01623-00	3	
18	Diaphragm Bolt	Steel	05-04764-00	12	Cast Iron Body
	Diaphragm Stud	Steel	05-05490-00	12	Steel Body
19	Stem <sup>1</sup>	St. Steel	04-05229-00	1	
20	Screen <sup>1</sup>	St. Steel	04-04700-00	1	Steam Service
	Screen <sup>1</sup>	St. Steel	04-04701-00	1	Water Service
21	Disc <sup>1</sup>	Seco Metal	04-01772-90	1	
22	Stem Nut <sup>1</sup>	Steel	05-02888-00	2	Steam Service
	Stem Nut <sup>1</sup>	Brass	05-02886-00	2	Water Service
23	Blind Flange Bolt	Steel	05-04803-00	4	Cast Iron Body
	Blind Flange Bolt	Steel	05-11719-00	4	Steel Body
	Repair Kit - Hard	Cast Iron Pilot	07-04164-00		
	Repair Kit - Hard	Steel Pilot	08-10375-00		
	Repair Kit - Soft	Cast Iron Pilot	08-08556-00		
	Repair Kit - Soft	Steel Pilot	08-10379-00		

1. These parts furnished in Repair Kit



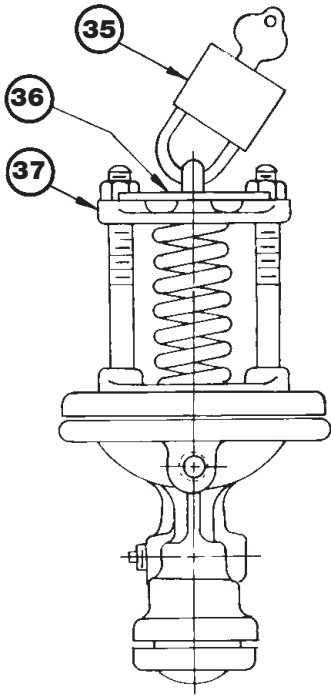

**Locking Device**

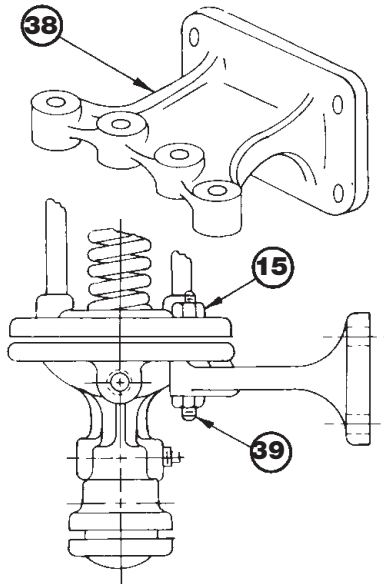

**Wall Bracket**

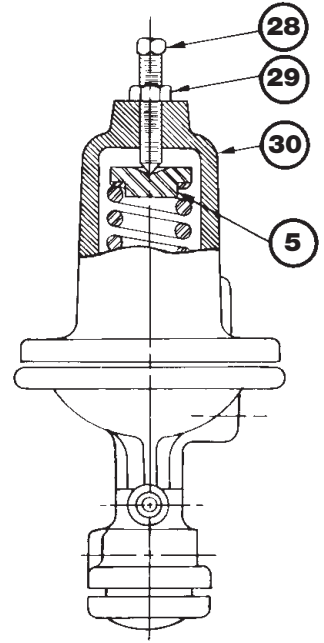

**Enclosed Spring Chamber**

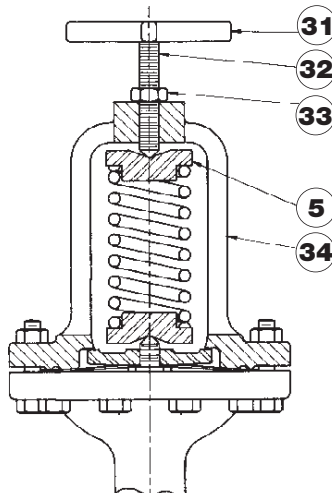

**Adjusting Handwheel**

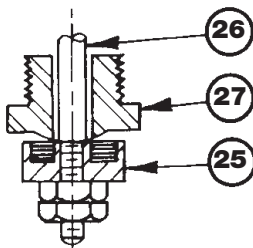

**Composition Disc**

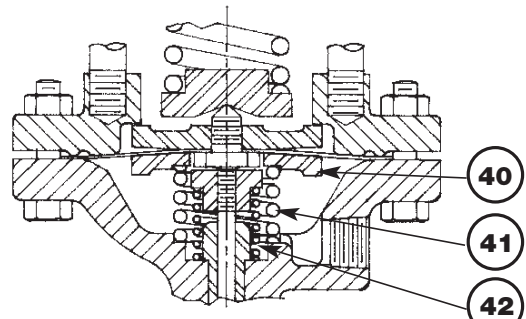

**Vacuum Spring Assembly**

**TABLE 3 - OPTIONS**

ITEM NO.	PART NAME	MATERIAL	PART NO.	QUANTITY	REMARKS
----------	-----------	----------	----------	----------	---------

**LOCKING DEVICE**

35	Padlock	Brass	05-03204-00	1	
36	Lock Bar	Steel	04-00436-00	1	
37	Spring Yoke Ass'y	Iron	07-43507-00	1	

**WALL BRACKET**

15	Diaphragm Nut	Steel	05-02871-00	1	Iron Body
	Diaphragm Nut	Steel	05-02845-00	4	Steel Body
38	Wall Bracket	Cast Iron	04-01029-00	4	
39	Diaphragm Bolt	Steel	05-04766-00	4	Iron Body
	Diaphragm Stud	Steel	05-05462-00	8	Steel Body

**COMPOSITION DISC**

25	Disc Assembly <sup>1</sup>	Brass	07-53512-00	1	
26	Stem <sup>1</sup>	St. Steel	04-05381-00	1	
27	Seat Ring <sup>1</sup>	St. Steel	04-04060-00	1	

**ENCLOSED SPRING CHAMBER**

28	Adjusting Screw	Steel	05-04860-00	1	
29	Locknut	Steel	05-02942-00	1	
30	Spring Chamber	Iron	04-01393-00	1	
	Spring Chamber	Bronze	04-01395-00	1	
	Spring Chamber	Steel	04-01394-00	1	
	Enclosed Spring Chamber Kit	Cast Iron	08-01868-00		

**ADJUSTING HANDWHEEL**

31	Handwheel	Aluminum	04-12985-01	1	
32	Adjusting Screw	Steel	04-04752-02	1	
33	Locknut	Steel	05-02942-00	1	
34	Yoke	Cast Iron	04-06170-00	1	Iron Body
	Yoke	Ductile Iron	04-06167-02	1	Steel Body
	Handwheel Kit	Cast Iron	08-01867-00		

**VACUUM SPRING ASSEMBLY**

40	Floating Plate	Iron	04-03710-00	1	
41	Vacuum Spring	302 St. Steel	05-05055-00	1	
42	Valve Spring	Inconel	05-09353-00	1	

1. These parts furnished in Repair Kit

# MAINTENANCE

(Parentheses refer to item number)

## REQUIRED TOOLS

- 2 Socket Wrenches
- Adjustable Wrench
- 3/16" Allen Wrench
- Wire Brush
- Prick Punch
- Grinder
- Crocus Cloth
- Solvent
- Travel Gage (Included in Repair Kit)
- Lapping Compound (500grit)
- Deep Sockets: 3/8", 7/16", 9/16", 11/16"
- Sealing Compound (Copaltite or Equivalent)

## DISMANTLING

- 1 – Release adjusting spring (4) compression by loosening adjusting nuts (1). Remove nuts, yoke (2), adjusting spring, and spring button (5).
- 2 – Remove diaphragm nuts (15) and lift off cowl (6). Lift out diaphragm assembly (7, 16 & 17).
- 3 – Disassemble diaphragm assembly by removing diaphragm screw (7) from pressure plate (16). This step is not necessary if installing a new diaphragm assembly (included in repair kit).
- 4 – Remove blind flange bolts (23) and take off blind flange (14). Remove screen (20) and gasket (13).
- 5 – Hold the pusher plate (8) and remove stem nuts (22). Lift out stem assembly (8 & 19) and valve spring (9). The disc (21) will drop off. If the disc is not easily removed from the stem (19), or the stem does not easily move in the the bushing (10) or is difficult to remove, inspect stem, seat ring (11), and disc carefully for notches, scratches or bending.
- 6 – Remove the seat ring from the pilot body (12) using a socket wrench. Do not remove the seat ring unless replacing the stem assembly and disc.

## INSPECTION

- 1 – Examine the seat ring (11) and disc (21) sealing surfaces for nicks or other signs of damage by pipeline debris. Slight imperfections may be removed by lapping the surfaces. Otherwise, the seat ring and disc must be replaced.
- 2 – Examine the stem (19) for a build-up of pipeline contaminants or erosion. Remove any build-up with a wire brush and polish with a very fine crocus cloth. Work carefully to avoid bending the stem.
- 3 – Inspect the pilot body (12) and its ports for corrosion. Some rust is normal, but if corrosion debris is readily separated from the body, clean body with wire brush and remove debris.

## LAPPING OPERATIONS

Lap sparingly using 500 grit lapping compound and light pressure. Heavy grinding may cause galling, wide sealing surfaces and a grooved disc, all of which tend to produce leakage.

Lapping may be done using a socket wrench to rotate the stem and disc assembly back and forth against the seat for 30 seconds or so. After the sealing surfaces are lapped in, disassemble and clean all parts.

## SEAT, DISC AND STEM REPLACEMENT

- 1 – Clean the body threads of old sealing compound using a wire brush. Apply new sealing compound (Copaltite or equal) to the shoulder of the seat ring (11). Let stand until tacky before installing in pilot body (12).
- 2 – Secure disc (21) to stem (19) with a stem nut (22). Apply lapping compound to the disc and insert this assembly into the pilot body (omit the valve spring (9)).
- 3 – Use a socket and extender to lap in the disc to seat joint. See Lapping Operations for more information.
- 4 – Screw pusher plate (8) onto the stem. Holding the disc firmly against its seat, adjust the pusher plate so that dimension C = 11/64" (See Figure 1). A gage (part number 05-02416-00) is supplied with each repair kit. Being careful not to disturb the pusher plate adjustment, use a prick punch to notch the stem threads above the pusher plate so that the pusher plate can no longer rotate freely. Work carefully to avoid bending the stem. The valve travel is now set.
- 5 – Remove the stem nut and lift the stem assembly (19 & 8) out of the top of the pilot. Grind off the stem Projection B flush with the upper surface of the pusher plate. This can be done at the bench without removing the stem from the body as long as the grinder doesn't make contact with the mating surfaces of the pilot body.
- 6 – Reinsert the stem into the pilot body. Install disc and a stem nut.
- 7 – Check that the valve travel A = 3/64". This need not be exact. Stem should move smoothly. Binding indicates a bent stem.
- 8 – Remove the stem nut and disc; withdraw stem. Install stem with valve spring, disc and both stem nuts.

## ASSEMBLY

- 1 – If the seat ring (11), disc (21), and stem (19) were not replaced, reinstall the seat ring first, then slide the valve spring (9) over the bushing (10) and slide the stem back into place. If they were replaced, skip to step 3.
- 2 – While holding the pusher plate (8) with a socket, install the seat ring (11) and stem nuts (22) one at a time.



3 – Install the screen (20) and gasket (13), and, using the blind flange bolts (23), reinstall blind flange (14). When replacing gaskets, be sure that any serrated sealing surfaces are cleaned of old gasket material.

Be sure to apply sealing compound (Copaltite or equal) to the shoulder of the diaphragm screw. For steel body pilots only, apply sealing compound to the diaphragm flange of the pilot body as well.

4 – Assemble the diaphragm assembly (7, 16 & 17) by sandwiching the diaphragms (17) between the pressure plate (16) (flat side against diaphragm) and the diaphragm screw (7). The number of diaphragm discs depends on the adjusting spring range.

5 – Drop the diaphragm assembly into place (pressure plate up). Center the assembly and install the cowl (6). Install four diaphragm bolts or studs (18) and diaphragm nuts (15) equally around the cowl to ensure the diaphragm assembly is centered. Install the rest of the diaphragm nuts, bolts and/or studs and tighten in an opposing pattern.

0 – 8 psig	1 Diaphragm Disc
3 – 20 psig	2 Diaphragm Discs
5 – 50 psig	2 Diaphragm Discs
10 – 100 psig	2 Diaphragm Discs
20 – 150 psig	3 Diaphragm Discs

6 – Install the spring button (5), adjusting spring (4), spring yoke (2) and adjusting nuts (1).

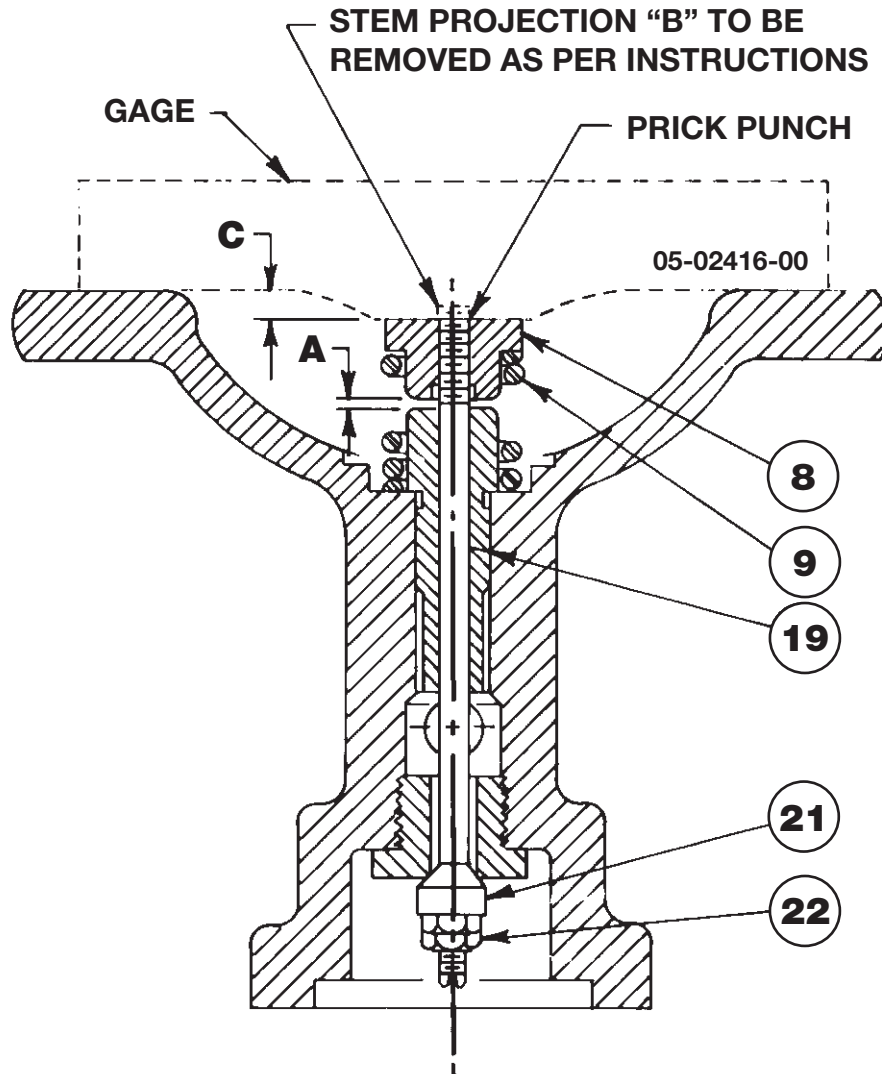

FIGURE 1 - TRAVEL SETTING