

Installation, Operation, and Maintenance Manual
Types PT and ETP
Dome-Loaded Pressure Regulator Valves



CAUTIONARY NOTE

It is important that the correct start-up and shut down procedures as outlined in this manual are followed

To avoid damage to the Regulator and Personal Injury.

TABLE OF CONTENTS

	Page
1. PRIOR TO INSTALLATION	2
2. INSTALLATION	3
3. OPERATION	4
4. MAINTENANCE	5-6
5. TROUBLESHOOTING	7

LIST OF ATTACHMENTS:

DRAWING:	PT <u>A8001</u>, DATED <u>10/09/00</u>	8
	PT <u>A8005</u>, DATED <u>10/09/00</u>	9
PHOTOGRAPHS:	<u>PT3/PT4 HOOK-UP</u>	10
SKETCHES:	<u>HOOK-UP SKETCH 7</u>	11

I. PRIOR TO INSTALLATION

- 1.1 Upon receipt of the regulator, inspect for any damage that may have occurred during shipping.
- 1.2 Check the nameplate on the regulator to ensure it conforms with what was ordered. The serial number is of utmost importance for purposes of future reference of the regulator. Please record this number and provide with all future correspondence, or ordering parts.
- 1.3 The regulator and piping internal surfaces should be clean and free of debris. A filter or strainer may be necessary upstream of the regulator for improved performance.

THERMAFLO ENGINEERING	<input type="text"/>
SERIAL NUMBER	<input type="text"/>
Tel 704 940 1228	
Fax 704 940 1227	MODEL NUMBER <input type="text"/>
	PRESSURE RATING <input type="text"/>

II. INSTALLATION

2.1 Installation Guidelines:

- a) Provide space below, above, and around the regulator to allow for removal of parts during maintenance.
- b) In screwed end regulators, use pipe compound sparingly on male threads only.
- c) Install isolation valves and pressure gauges to provide means for adjustment, operation, by-pass, or removal of the regulator.
- d) The operating temperature/pressure must never exceed the maximum allowable rating of the regulator.
- e) When using the valve on steam service always locate trap station and strainer as close to the inlet as possible

2.2 Valve Position

Install the valve with the flow in the direction of the arrow cast or stamped into the valve body. For liquids bleed off any trapped air through the external sensing port (port “ A “).

2.3 Recommended Piping Dimension:

For best performance, it is recommended that the piping upstream and downstream of the regulator be straight and free from any restrictions for a

- a) minimum length of approximately five (5) to twenty-five (25) pipe diameters. For external sensing, the sensing point should be downstream, at a point of minimum turbulence, usually 10-15 pipe diameters. Pipe size should be given special consideration, particularly downstream of the regulator, to ensure that the fluid velocity does not exceed industry standards / guidelines. Expanders may need to be utilized to accomplish this. Improperly sized outlet piping with cause noise and reduce the capacity.
- b)

2.4 Considerations for Valves with External Sensing

- a) The Type PT valve may be installed with internal or external sensing (never both). The valve may be easily converted in the field from one sensing mode to the other.
- b) Generally, external sensing is used when the effects of downstream system pressure losses (fluid friction, velocity flow) can be significant. For valves set up for external sensing, use an external control line. The line is connected from the port (1/4” NPT) on the side of the body flange to a point of minimum turbulence as described in paragraph 2.3 above. Use 1/4” outer diameter tubing or pipe having an inner diameter equivalent to schedule 40 pipe. Slope the external sensing line downward 2° to 5° to the downstream piping to prevent water pockets.
- c) For valves out fitted with external sensing and if there is an isolation or shut off valve downstream of the regulator, make sure the isolation or shut off valve is downstream of the external sensing connection. In addition, if there are any internal sources in the system for high pressure build up, make sure that the regulator is isolated from such build up by isolation valves both upstream and downstream and that they are in the closed position during such build up.

III. OPERATION

3.1 General:

The valve is normally closed by spring. Pressure enters the inlet port and flows through the seat orifice and out of the valve. The downstream pressure is sensed on the underside of the diaphragm by either an internal sensing port within the valve body, or by means of an external sensing line. Note that unless specified by the customer at the time of order, the valve has internal sensing. If external sensing is utilized, ensure that a control line is connected from the external sensing port to the desired sensing location in the process.

- a)
- b)

The downstream pressure, is pressure pushing up on the diaphragm, and is opposed by the loading pressure in the dome, that pushes down on the diaphragm. The valve plug will move up or down until these two forces are equal, this occurs when the downstream pressure equals set point.

The required top loading pressure will be somewhat higher than the desired set point. This difference between set point and required loading pressure is a function of the valve size and inlet pressure. The loading pressure will need to be determined in the field under actual flowing conditions, and can only be ascertained by reading pressure gauges. In most cases the outlet pressure is 1 psig with 5 psig top loading pressure.

- c)
- d)

To adjust the reduced pressure, simply adjust the dome loading pressure until the desired reduced pressure is achieved.

3.2 Start-up Procedure:

- a) Open the outlet isolation about ¼ open valve.
- b) Slowly open the inlet isolation valve.
- c) Readjust the outlet stop valve to permit a slight flow when adjusting the Type PT regulator.
Slowly increase the dome loading pressure until the valve begins to open.
- d) Gradually increase the loading pressure until the desired downstream pressure is obtained.
- e) Gradually open the outlet stop valve.
Readjust fully the dome loading pressure to obtain the desired downstream pressure setting at a desired flow condition (*i.e.* –low flow, medium flow, high flow, etc.)
- f) To increase the downstream pressure, increase the dome loading pressure. To decrease the downstream pressure, decrease the dome loading pressure. With a temperature control application this is done automatically by the I/P transducer and digital process controller.
- g)

3.3 Shut-down Procedure:

- a) Shut off the inlet stop valve
- b) Allow sufficient time for the trapped pressure between the inlet stop valve and the Type PT valve to bleed down to the set pressure.
- c) Relieve the dome-loading pressure to zero (0) psig.
- d) Shut off the outlet isolation valve
- e) Relieve the trapped upstream and downstream pressures
- f) The regulator may now be disassembled for inspection. Always wear protective apparel when operating or dismantling the valve.

Note: In some cases the PT valve is fitted with an electronic pilot for temperature and pressure control on the TH-250, TH-750ZX Zeroflash and TH-750VX Vacuflo heaters. The maintenance and operation considerations are the same.

IV. MAINTENANCE

4.1 General:

- a) The Type PT valve may be serviced without removing it from the pipeline. The regulator is especially designed with quick-change trim for easy maintenance.
- b) Check the nameplate for **serial number**, Model number (valve size, body material, type number, pressure rating, and sensing number).
- c) If external sensing is used, be sure that the external sensing (control) line is connected.

REFER TO DRAWING A8001 FOR RECOMMENDED SPARE PARTS. USE ONLY ORIGINAL EQUIPMENT SUPPLIED BY THERMAFLO ENG. FOR RE-BUILD OR REPAIR OF TYPE PT REGULATORS.

4.2 Disassembly Procedure for Regulators with Elastomeric Membranes:

- a) Shut down the system in accordance with Sub-section 3.3.
Remove the cover (P/N 2) by removing the body nuts (P/N 52) and body bolts (P/N 51). **BE SURE TO ELIMINATE ALL COVER PRESSURE PRIOR TO REMOVAL OF THE COVER.**
- b) Remove the membrane nut (P/N 50). When removing this nut, hold the valve stem (P/N 4) by the Hex on the top of the stem. Remove the upper (P/N 7) and lower (P/N 6) membrane plates along with the membrane (P/N 9).
- c) Remove the cylinder bolts (P/N 53).
- d) Remove the complete inner trim by pulling up on the valve stem. The inner trim resembles the trim shown in **Figure 1**.

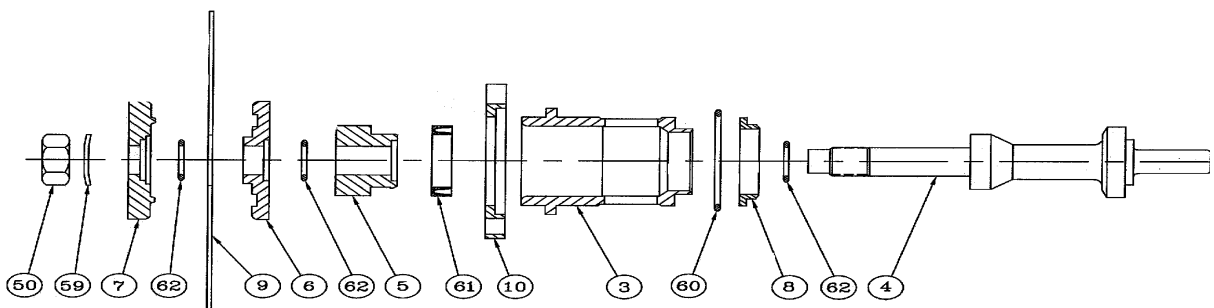

FIGURE 1

- f) Disassemble the complete inner trim by pulling the valve stem out of the piston. Inspect all of the parts for deterioration/damage
Check and replace as required all soft goods. Check with factory or your local Thermaflo Valve sales representative for price and availability for parts (rebuild)
- g) kits. Be sure to provide the valve serial number when ordering. **USE ONLY FACTORY SUPPLIED PARTS FOR PROPER RECONDITIONING.**

4.3 Disassembly and Reassembly Procedure for Regulators with Metal Diaphragms:

- a) Shut down the system in accordance with Subsection 3.3
Remove the cover (P/N 2) by removing the body nuts (P/N 52) and body bolts (P/N 51). **BE SURE TO ELIMINATE ALL COVER PRESSURE PRIOR TO REMOVAL OF THE COVER.**
- b) Lift off the multi-ply membrane set.
- c) Remove the cylinder bolts (P/N 53). Remove the complete inner trim by pulling up on the piston (P/N 5). The inner trim resembles the trim shown in **Figure 2**

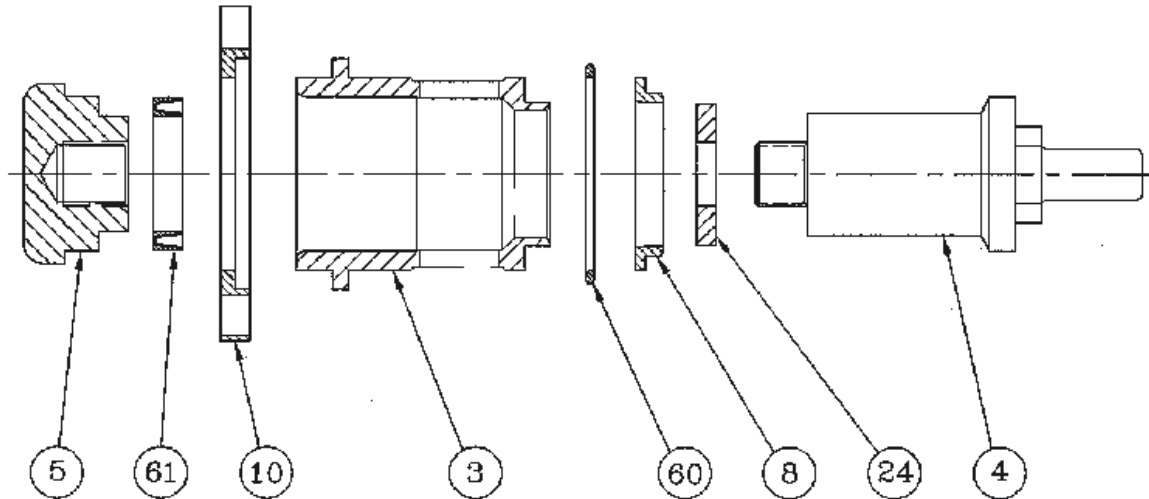

FIGURE 2

- e) To disassemble the complete inner trim, hold the two flats in the lower part of the valve stem (P/N 4) in a bench vise. **DO NOT HOLD ON THE MACHINED SURFACE IN THE SPINDLE AREA**
- f) Grasp the piston with a spanner wrench and turn counterclockwise to loosen. The piston can now be threaded off by hand.
- g) Lift off the cylinder and inspect the parts
Check and replace as required all soft goods. Check with factory or your local Thermaflo Valve sales representative for price and availability or parts (rebuild) kits. Be sure to provide the valve serial number when ordering. **USE ONLY FACTORY SUPPLIED PARTS FOR PROPER RECONDITIONING.**
- h) Reassemble the valve by reversing the disassembly procedure.
- i) The cylinder bolts should torque to 15-18-ft. lbs.
- j) The body bolts should torque to 1/2" to 1-1/2" 28-32 ft. lbs. 2" to 4" 35-40 ft. lbs.
- l) The membrane gasket should be installed under the membranes in contact with the fluid.

4.4 Reassembly-Critical for Long Service

- a) Reassemble the valve by reversing the applicable disassembly procedure.
TORQUE values for membrane nuts 70-80 ft.- lbs on 1/2" - 1" size valves and 120-130 ft.-lbs. On 1-1/2 " and larger size valves. Wait at least 15 minutes and re-torque the membrane nut again. The torque value decreases because the membrane material takes a compression set. **ONLY AFTER THE MEMBRANE**
- b)

NUT RETAINS THE SPECIFIED TORQUE VALUE SHOULD THE REASSEMBLY CONTINUE. THE TORQUE IS CRITICAL IN ORDER TO OBTAIN THE MAXIMUM LIFE FROM THE STEAM MEMBRANE ASSEMBLY.

V. TROUBLESHOOTING

Below is a partial list of potential difficulties that may be encountered along with corresponding possible causes and remedies.

OBSERVED PROBLEM	POSSIBLE CAUSE	REMEDY
Overshooting delivery pressure, or failure of main valve to close.	<ul style="list-style-type: none"> • The I/P may not not be zeroed correctly or leaks • Valve may be held open due to dirt or scale on seat 	<ul style="list-style-type: none"> • Readjust as necessary • Clean and/or replace parts as necessary
Hunting	<ul style="list-style-type: none"> • Valve may be sticking due to debris buildup on stems and guiding passages 	<ul style="list-style-type: none"> • Clean and/or replace parts as necessary
Sagging delivery pressure, or failure of main valve to open.	<ul style="list-style-type: none"> • Setting of adjusting spring may have been tampered with • Initial pressure (noted on pressure gauge at inlet to valve) may be down • Sensing port (or line if external sensing is used) may be plugged 	<ul style="list-style-type: none"> • Readjust as necessary • Confirm initial pressure is at minimum required level to obtain desired delivery pressure • Clean as necessary

Note: All Thermaflo PT valves are furnished with Rulon LD final soft seats and will provide class 6 dead tight shutoff, unless dirt, scales, or boiler chemicals such as filming emines are building up on the seats. A steam trap located at the inlet of the valve will help to eliminate this. Also it is highly recommended to install a strainer and or steam separator on the inlet.

VALVE SIZE	1"	1 1/8"	1 1/2"	2"	3"	4"	5"	6"	8"	10"	12"
1/8" 9/16" 1"	8"	8 7/8"	9 1/2"	10 3/4"	11 1/8"	11 1/2"	11 3/4"	12 1/8"	12 3/4"	13 1/2"	14 1/8"
1 1/8"	8 7/8"	9 1/2"	10 3/4"	11 1/8"	11 1/2"	11 3/4"	12 1/8"	12 3/4"	13 1/2"	14 1/8"	14 1/2"
2"	8 7/8"	9 1/2"	10 3/4"	11 1/8"	11 1/2"	11 3/4"	12 1/8"	12 3/4"	13 1/2"	14 1/8"	14 1/2"
3 1/2"	10 7/8"	11 1/8"	11 1/2"	11 3/4"	12 1/8"	12 3/4"	13 1/2"	14 1/8"	14 1/2"	15 1/4"	15 3/4"
3"	11 3/4"	12 1/8"	12 3/4"	13 1/2"	14 1/8"	14 1/2"	15 1/4"	15 3/4"	16 1/2"	17 1/8"	17 1/2"

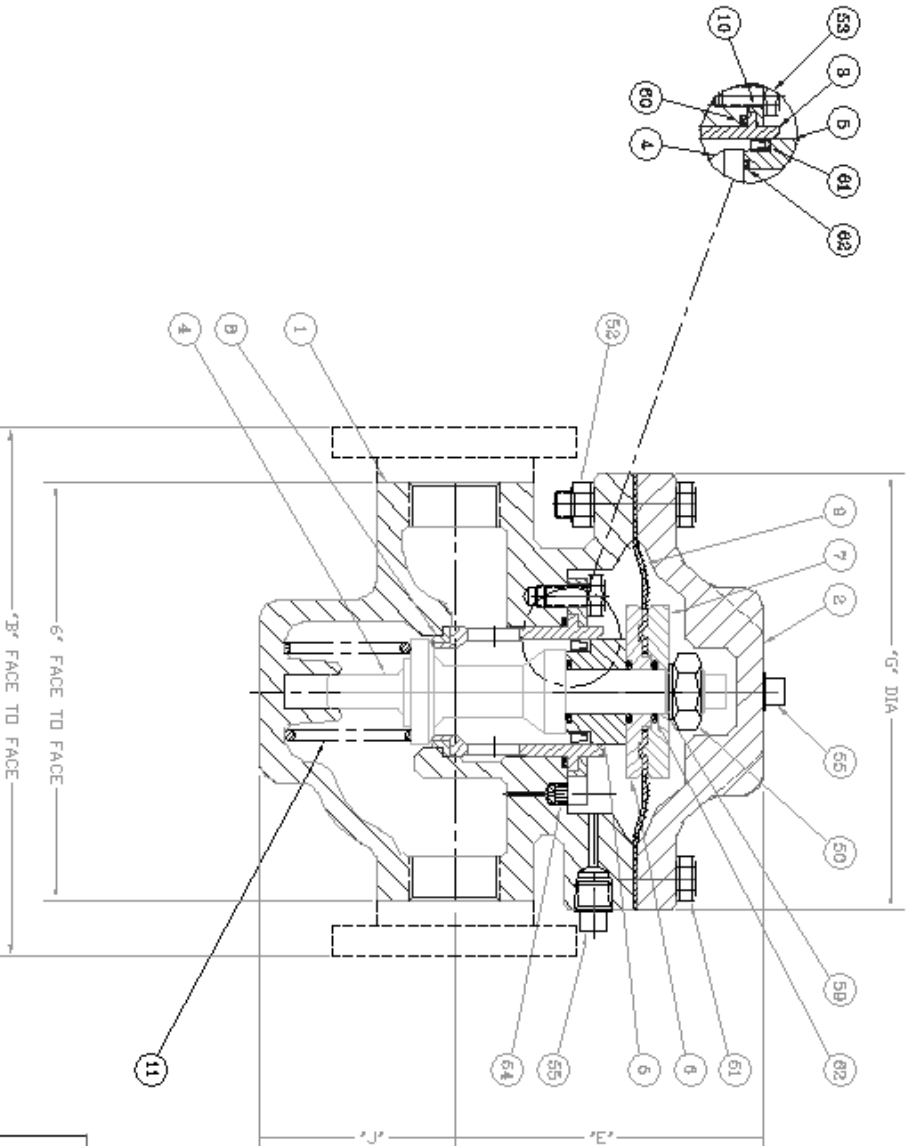

ITEM NO.	QTY	DESCRIPTION
11	1	MAIN SPRING
10	1	CYLINDER PLANGE
9	1	MEMBRANE
8	1	SEAL
7	1	UPPER MEMBRANE PLATE
6	1	LOWER MEMBRANE PLATE
5	1	PISTON
4	1	STEM
3	1	CYLINDER
2	1	COVER
1	1	BODY

DRAWN BY: R.G.
 DATE: 10/9/00
 CHECKED BY: D.
 DATE: 10/9/00
 PART NO.: A8005
 TITLE: PRESSURE REDUCING VALVE
 TYPE: BD (I-CUP)
 SIZE: 1/2" TRD 3"



Hook Up Sketch of Dome Loaded Regulator

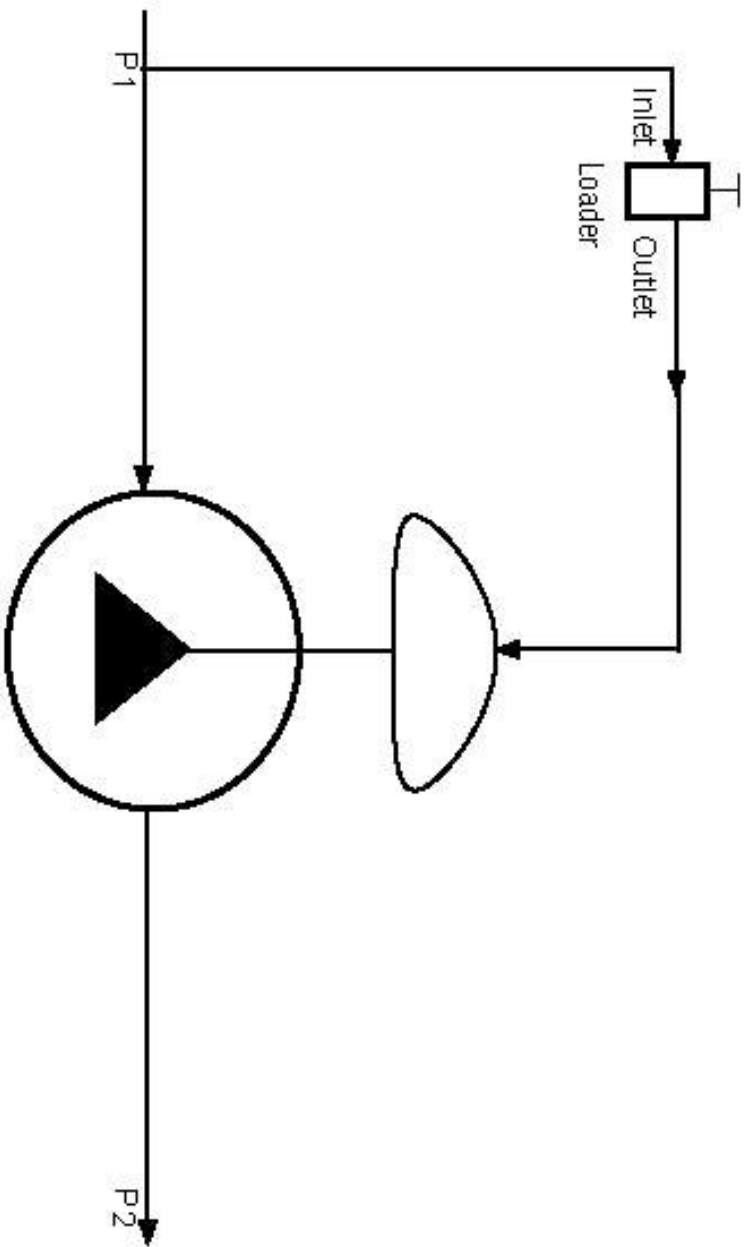

Regulator Valve

Hook Up Sketch: 7

01/22/03